

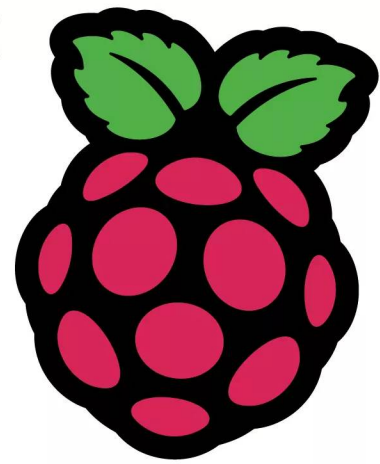

YOUR OFFICIAL RASPBERRY PI MAGAZINE

The MagPi



Issue 143

July 2024

magpi.cc

The official Raspberry Pi magazine

ROBOT EXPLORERS!

SMART SCIENCE WITH SENSOR-PACKED ROVERS



£5.99

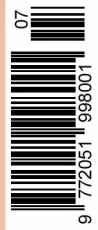

9 772051 998001

RETRO GAMING
MAGIC MIRROR

GET BANG ON TIME
WITH PYTHON DATES

10 AMAZING
COOKING PROJECTS!



ALL-NEW RASPBERRY PI **AI KIT** RELEASED

Industrial Raspberry Pi **ComfilePi**



The ComfilePi is a touch panel PC designed with high-tolerant components and no moving parts for industrial applications. It features a water-resistant front panel, touchscreen, color LCD (available in various sizes), RS-232, RS-485, Ethernet, USB, I2C, SPI, digital IO, battery-backed RTC (real-time clock), and piezo buzzer.

Use the rear-panel 40-pin GPIO header to expand its features and capabilities with additional I/O boards. The ComfilePi is UL Listed and employs Raspberry Pi Compute Module.

Visit www.comfiletech.com

© copyright COMFILE Technology, Inc. ALL RIGHTS RESERVED

COMFILE
TECHNOLOGY

WELCOME

to The MagPi 143

Robots are a true passion here at *The MagPi*. Few things you make with computers have the same potential to impress as a walking, wheeling, or even talking 'bot.

The real skill isn't just building a robot that rolls around, but creating a smart rover that can sense its environment and react accordingly. These rovers are sent into hazardous environments, or even to other planets.

Our robot explorer feature (**page 40**) has everything you need to get rolling.

Have fun building your robot, and don't forget to give it a name. And when you're done check out the new AI Kit (**page 8**). This new Raspberry Pi kit offers the potential to vastly speed up artificial intelligence projects. We can't wait to start making with it, and I know our community will put it to good use.

Making intelligent robots is a childhood dream and, thanks to Raspberry Pi, it's now possible. I can't wait to see what you all make with it.

Lucy Hattersley Editor



EDITOR
Lucy Hattersley

Lucy is the editor of *The MagPi* and her favourite fictional robot is Marvin. But don't tell him. It'll only bring him down.

magpi.cc

GET A
**RASPBERRY PI
PICO W**
WITH A SUBSCRIPTION!
PAGE 38



The parts we sell help lives become richer

Imagine hearing aids that let a child experience her parents' voice clearly for the first time.

At DigiKey, the parts we sell help companies turn innovative, game-changing ideas into real-world solutions that change lives.

Find your part at [digikey.co.uk](https://www.digikey.co.uk)



DigiKey

we get technical

DigiKey is a franchised distributor for all supplier partners. New products added daily. DigiKey and DigiKey Electronics are registered trademarks of DigiKey Electronics in the U.S. and other countries. © 2024 DigiKey Electronics, 701 Brooks Ave. South, Thief River Falls, MN 56701, USA

ECIA MEMBER
Supporting The Authorized Channel

Contents

► Issue 143 ► July 2024

Cover Feature

40 Robot explorers

Regulars

- 08 World of Raspberry Pi
- 34 Case Study: Homey Pro
- 90 Your letters
- 92 Community events calendar
- 97 Next month
- 98 The Final Word

Project Showcases

- 12 Spin
- 16 Dicemaster 2000
- 20 Colour Word Clock
- 24 PUTTR
- 28 Math GPT
- 32 Retro Gaming Magic Mirror

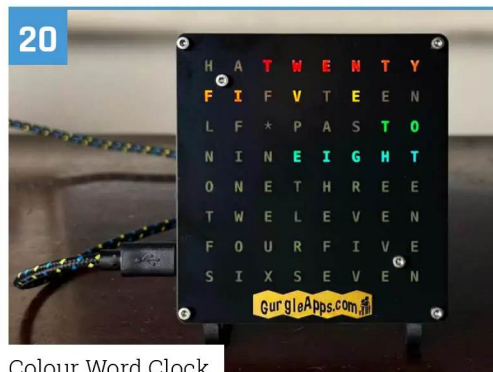

Colour Word Clock



40



16

Dicemaster 2000

The MagPi is published monthly by Raspberry Pi Ltd, 194 Cambridge Science Park, Milton Road, Cambridge, England, CB4 0AB. Publishers Service Associates, 2406 Reach Road, Williamsport, PA, 17701, is the mailing agent for copies distributed in the US and Canada. Application to mail at Periodicals prices is pending at Williamsport, PA. POSTMASTER: Send address changes to The MagPi, c/o Publishers Service Associates, 2406 Reach Road, Williamsport, PA, 17701.

Tutorials

- 48** Add M.2 HAT+ to Raspberry Pi 5
- 52** Experiment with time in Python
- 58** Build a Raspberry Pi cash register

The Big Feature



64

Raspberry Pi success stories

48



Add M.2 HAT+ to Raspberry Pi 5

58



Raspberry cash

74

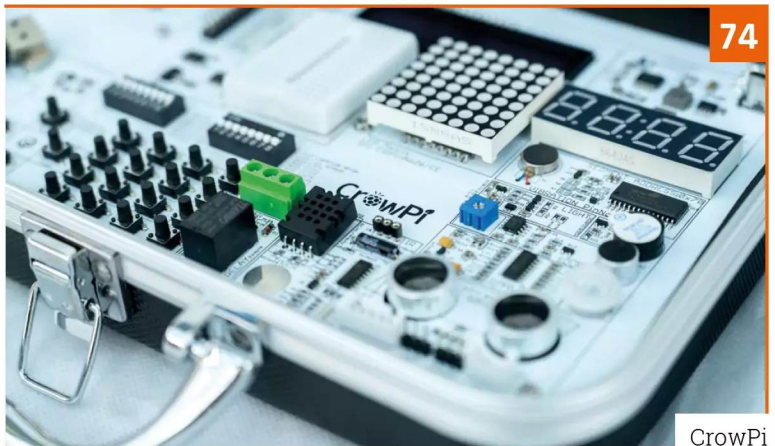

CrowPi

Reviews

- 72** PiDP0-10
- 74** CrowPi electronics kit
- 76** ED-IPC
- 80** Ten amazing cooking projects
- 82** Learn Java

Community

- 84** Brian O'Halloran interview
- 86** This Month in Raspberry Pi

84

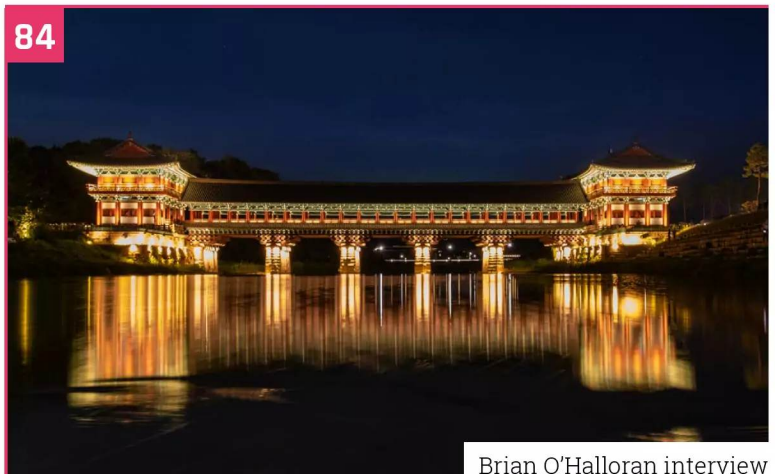

Brian O'Halloran interview

WIN
1 OF 5 **RASPBERRY PI AI KITS** **94**

DISCLAIMER: Some of the tools and techniques shown in The MagPi magazine are dangerous unless used with skill, experience, and appropriate personal protection equipment. While we attempt to guide the reader, ultimately you are responsible for your own safety and understanding the limits of yourself and your equipment. Children should be supervised. Raspberry Pi Ltd does not accept responsibility for any injuries, damage to equipment, or costs incurred from projects, tutorials or suggestions in The MagPi magazine. Laws and regulations covering many of the topics in The MagPi magazine are different between countries, and are always subject to change. You are responsible for understanding the requirements in your jurisdiction and ensuring that you comply with them. Some manufacturers place limits on the use of their hardware which some projects or suggestions in The MagPi magazine may go beyond. It is your responsibility to understand the manufacturer's limits.

Design

Code

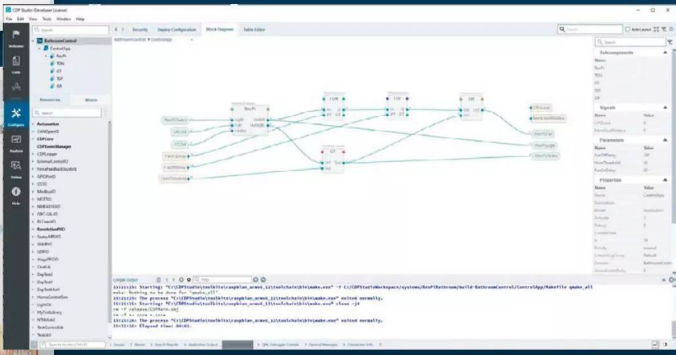
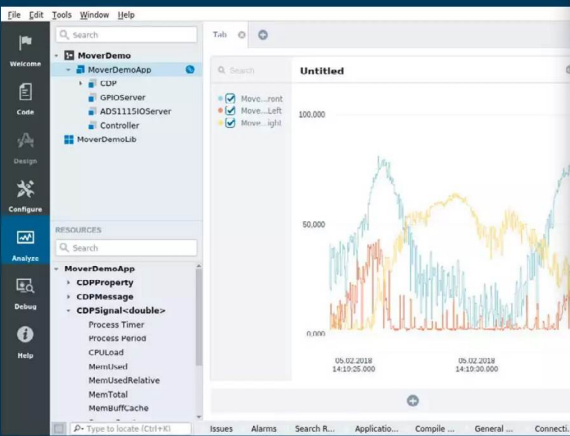
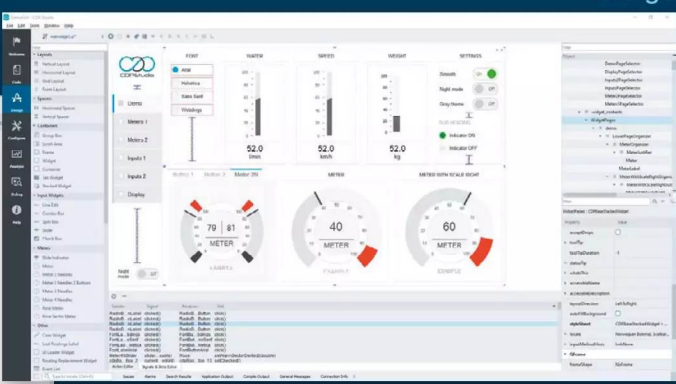
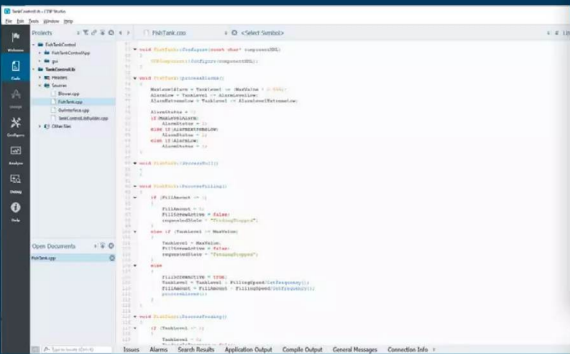

Configure

Analyze

PROFESSIONAL CONTROL SYSTEM DEVELOPMENT TOOL

Home projects made easy.

CDP Studio, a great software development tool for your home projects. Build systems for Raspberry Pi, use C++ or NoCode programming, open source libraries, out of the box support for GPIO, I2C, MQTT, OPC UA and more. Create beautiful user interfaces. Built for industrial control system development, **FREE for home projects.**

cdpstudio.com

Tel: +47 990 80 900 • info@cdptech.com

CDP Technologies AS // Hundsværgata 8, 6008 Ålesund, Norway



Raspberry Pi AI Kit

available now at \$70

Discover neural networks and integrate AI into your projects with AI Kit.

By **Naush Patuck**

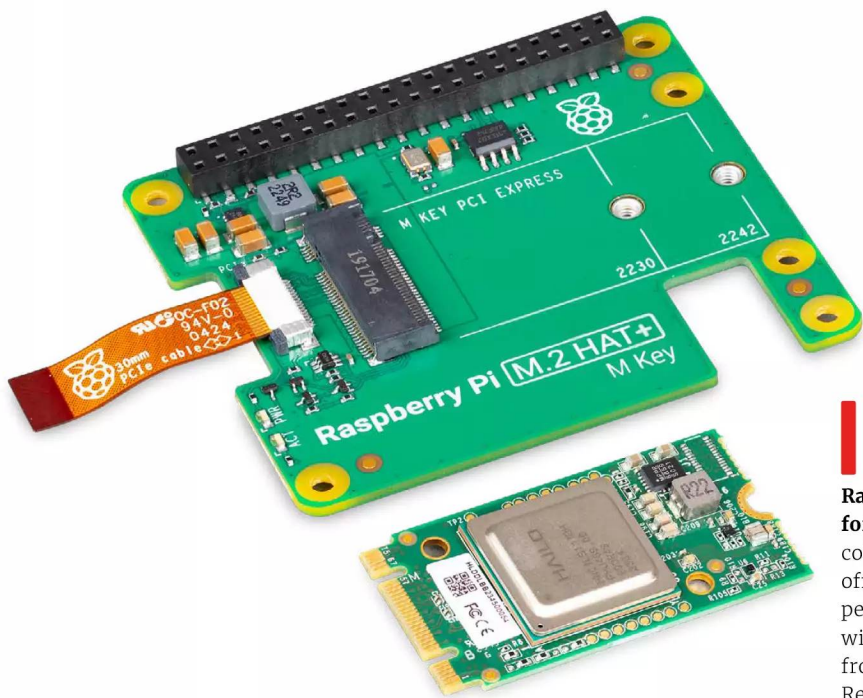

“Running in real time, with low latency and low power requirements”

If you've ever wanted to experiment with the world of neural networks, artificial intelligence and machine learning on your Raspberry Pi 5, we have the perfect product for you: the Raspberry Pi AI Kit. Developed in collaboration with Hailo (hailo.ai), the AI Kit offers an accessible way to integrate local, high-performance, power-efficient inferencing into a wide variety of applications. It's available today from our network of Raspberry Pi Approved Resellers, priced at just \$70 (approx £55).

The Raspberry Pi AI Kit comprises our M.2 HAT+ preassembled with a Hailo-8L AI accelerator module. Installed on a Raspberry Pi 5 (magpi.cc/raspberrypi5), the AI Kit allows you to rapidly build complex AI vision applications, running in real time, with low latency and low power requirements. State-of-the-art neural networks for object detection, semantic and instance segmentation, pose estimation, and facial landmarking (to name just a few) run entirely on the Hailo-8L co-processor, leaving the Raspberry Pi 5 CPU free to perform other tasks.

▲ The Raspberry Pi AI Kit disassembled



Key features of the Raspberry Pi AI Kit include:

- 13 tera-operations per second (TOPS) of inferencing performance
- A single-lane PCIe 3.0 connection running at 8Gbps
- Full integration with the Raspberry Pi image software subsystem
- Compatibility with first-party or third-party camera modules
- Efficient scheduling of the accelerator hardware: run multiple neural networks on a single camera, or single/multiple neural networks with two cameras concurrently

Hailo has created an extensive model zoo, where users can find a wide variety of pre-trained neural network models ready to deploy and optimised to run on the AI Kit.

The software

A significant hurdle in creating real-world AI-based vision applications is the software complexity of integrating the camera subsystem with the AI framework. We have worked hard to simplify this as much as possible. Our `rpicam-apps` suite of camera applications (magpi.cc/camapps) now has a post-processing template for integrating neural network inferencing running real-time in the camera pipeline. By using the pre-installed Hailo Tappas post-processing libraries (magpi.cc/tappasgit), we are able to create advanced AI-based applications in only a few hundred lines of C++ code. Similar levels of integration into our Picamera2 framework (magpi.cc/picam2git) will follow soon.

The software installation steps are very simple. Install a few packages through `apt`, reboot, and you are ready to try out some of our AI demos in a matter of minutes. The instructions can be found in our getting started guide (magpi.cc/aikitstart).

Here's a preview of some of our demos that you can run through `rpicam-apps`: With the Raspberry Pi AI Kit, you are not limited to using the Hailo-8L co-processor only in `rpicam-apps` or `Picamera2`. We also package an API integrated in the `GStreamer` framework (magpi.cc/gstreamer) and native Python or C/C++ applications. This also includes non-camera use cases, such as running inference on pre-recorded video files.

Further resources

Our documentation for the AI Kit (magpi.cc/aikitdoc) is a great place to start.

For full technical specifications for the Hailo-8L AI accelerator module, visit Hailo's product web page (magpi.cc/hailo8lm2).

Hailo has created a set of advanced AI applications (magpi.cc/hailopi5) running on a Raspberry Pi 5, and also has a community forum (magpi.cc/hailodev) for discussing topics specific to the Hailo-8L AI accelerator hardware and software tooling. 📄

▲ A closer look at the Hailo module

▼ Object recognition: the lemon Coke "bottle" is controversial in these parts

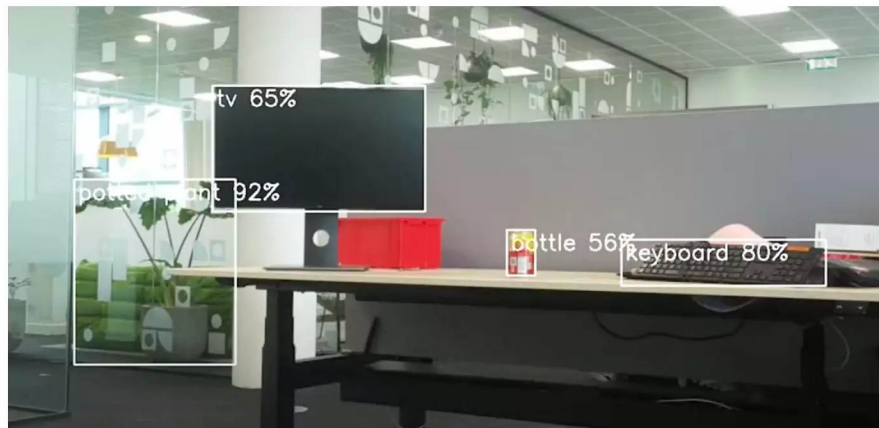

M.2 HAT+ on sale now at just \$12

Raspberry Pi PCIe expansion board is now available.
By **James Adams**, Director of Hardware

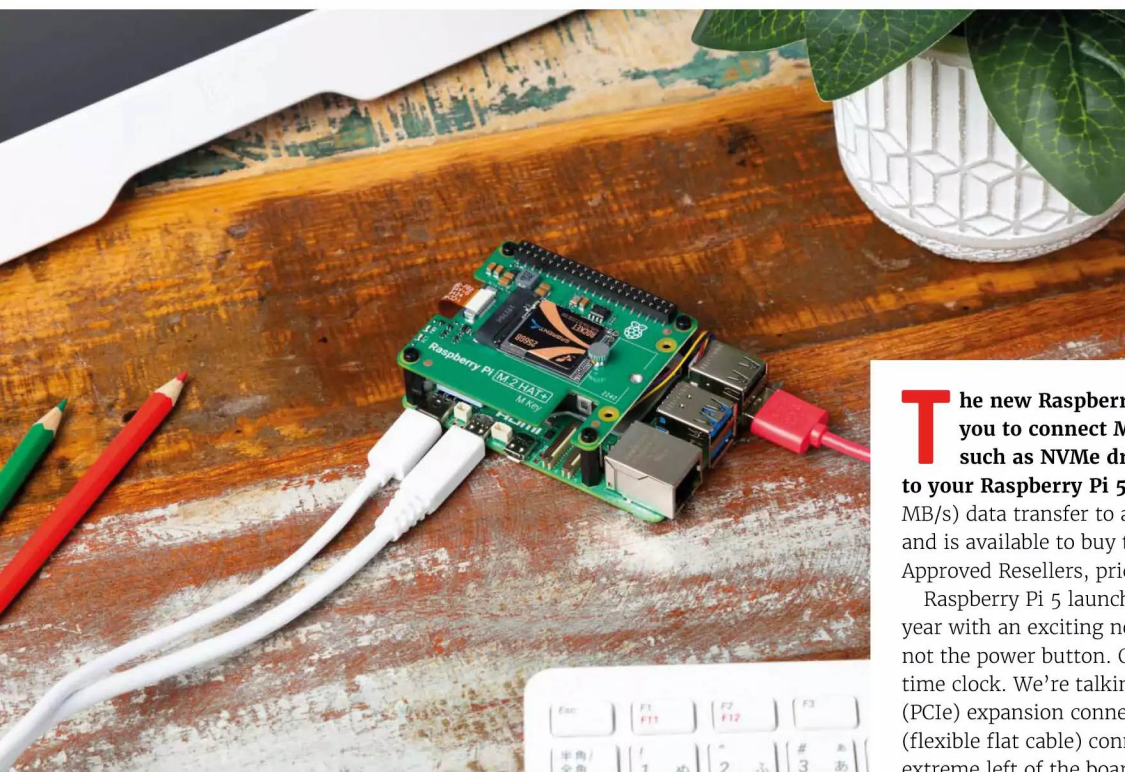

The new Raspberry Pi M.2 HAT+ enables you to connect M.2 M-key peripherals, such as NVMe drives and AI accelerators, to your Raspberry Pi 5. It provides fast (up to 500 MB/s) data transfer to and from these peripherals, and is available to buy today, from our network of Approved Resellers, priced at just \$12/£11.50.

Raspberry Pi 5 launched back in September last year with an exciting new feature on board. No, not the power button. Or the battery-backed real-time clock. We're talking about the PCI Express (PCIe) expansion connector: this small 16-way FFC (flexible flat cable) connector, positioned at the extreme left of the board where the MIPI display connector lives on older Raspberry Pi boards, carries a single-lane (one transmit pair, one receive pair, and one clock pair) PCIe 2.0 bus.

When we launched Raspberry Pi 5 we also showed off a prototype HAT+, which bridged between our FFC connector and the standard M.2 M-key form factor used by NVMe drives and many other small PCIe devices. After several revisions, simplifications, and a whole lot of testing, that prototype became the product you see today.

▲ M.2 HAT+ enables you to connect storage devices, such as this 256GB SSD drive, as well as PCIe devices like the new AI Kit

Developing great products takes time

Launching a new generation of Raspberry Pi computers is a huge effort, absorbing the attention of our engineering team. Raspberry Pi 5 was a particularly complex (and expensive!) programme, featuring three new custom chips (the Broadcom BCM2712 application processor, Dialog/Renesas DA9091 PMIC, and our own RP1 I/O controller); new production processes (intrusive reflow for connectors, and routed board singulation); and a completely redesigned production test system.

So while in an ideal world we would have launched the M.2 HAT+ at the same time as Raspberry Pi 5, it was important not to rush things. There were still a few unresolved questions, notably around the two “spare” pins on the 16-pin FFC connector. While these pins carried I2C signals in our earliest prototypes, in the end the Raspberry Pi PCIe Connector specification (magpi.cc/pciedocs) allocates them to fixed functions: one as a power enable for downstream device power, and one as a board detect and wake signal.

And we wanted to make sure that our product really was a HAT+, which in turn meant we had to resolve a few last wrinkles in the Raspberry Pi HAT+ specification (magpi.cc/hatplusspec). Raspberry Pi specifications, like our 40-pin GPIO connector and our three-pin debug connector, often become de facto standards for the rest of the industry, and we have a responsibility to get them right first time.

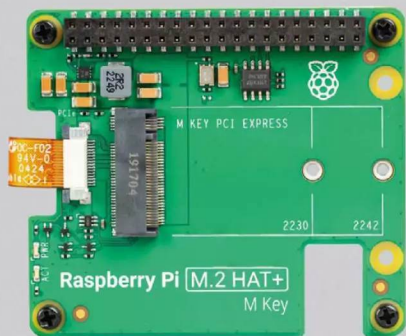

▲ Raspberry Pi's M.2 HAT+

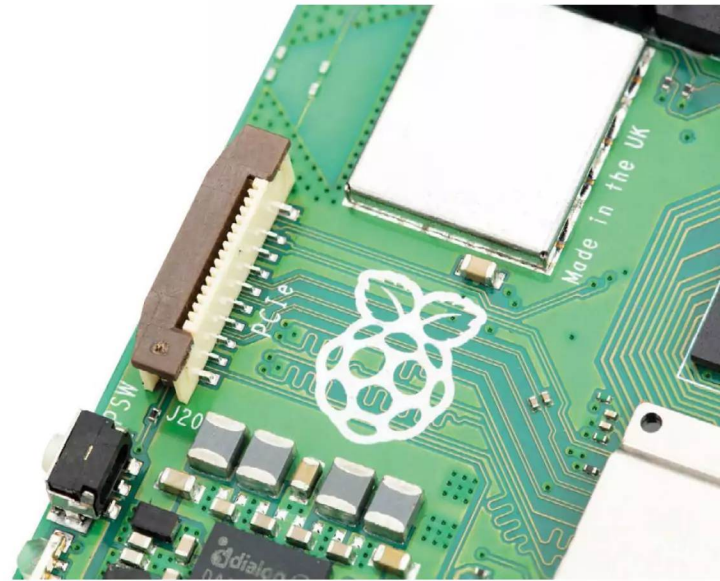

▶ Raspberry Pi 5's PCIe slot

“ we wanted to make sure that our product really was a HAT+ ”

Extensive drive compatibility

While we were doing all this, we took the opportunity to test a wide variety of NVMe drives and other peripherals, and to investigate the various issues we found. In one case we worked with a manufacturer to develop a fix for a drive that didn't work correctly; this one turned out to be a startup timing issue in the drive firmware, preventing the PCIe controller inside BCM2712 from recognising the drive.

And of course it takes time to write firmware, and to build the production processes, material pipeline, and test systems required to build tens of thousands of units of a product each and every month. But with all this done, we're pleased to be in a position to launch. If your Raspberry Pi 5 has up-to-date firmware, and an M.2 HAT+ attached, an installed PCIe device will be probed at power on and, if it's an NVMe drive, it will be available as a boot source.

Schematics

A nice side-effect of launching of the M.2 HAT+ a bit later has been all the third-party products, such as the NVMe Base (magpi.cc/nvmebase) from our friends at Pimoroni. We want to make it easier to build high-quality PCIe accessories for Raspberry Pi 5, and so we're publishing our schematics (magpi.cc/m2schem) as a reference design. You can also browse our documentation for the M.2 HAT+ online (magpi.cc/m2hatdocs).

Spin

Ever wondered what death metal disco sounds like? Spin will not only create it, but let you scratch it, too, as **Sean McManus** discovers



Arvind Sanjeev

Arvind is a design technologist who loves to experiment between the boundaries of the physical and digital.

magpi.cc/spin



Danger!
Mains Electricity

This project involves disassembling a mains-powered record player.

magpi.cc/electricalsafety

“My idea was to remove AI experiences from black boxes and put them into the physical world,” says Arvind Sanjeev. “It’s an open invitation for people to forget about the digital world and to try to create something with AI.”

His previous project was Ghostwriter, a typewriter which he converted to use text generator ChatGPT. Humans type their messages and Ghostwriter types its replies onto the same sheet of paper.

He wanted to create a family of devices and was thinking about where else AI has been disruptive. “The latest music AIs have become so good that it’s really hard to distinguish them from a human creator,” he says. “Spin is this curiosity tool that allows you to explore the boundaries of creating music with AI. I took a lot of inspiration from old analogue synthesisers and combined it with a digital vinyl system DVS.”

Using AI platforms, you usually describe what you want in text. “It’s hard for someone who’s using it for the first time to come up with a really nice prompt,” says Arvind. “I wanted to bring as much physicality into this interaction as possible, rather than using a keyboard to type in what you want.”

Play that funky music

At first glance, Spin looks like a record player. In fact, half of it is. The other half is a grid of buttons. One row allows you to select a mood, such as spacey, warm or dark. Two rows set the genre, including death metal, trance and jazz. Three rows are dedicated to sounds. There are instruments



(including drums, sitar, and violin) but also the sounds of water, nature and opera. There are no constraints on how many buttons you select, or what combinations you use. If you can’t decide, there’s a random button.

The duration of the music and tempo are set using sliders. Knobs control the volume and speed. “I thought: What are the maximum different kinds of physical interactions I can bring to this device?” Arvind says.

When you press the generate button, your chosen options are used to create music. When it’s ready, the record starts to rotate. “It is a signal or

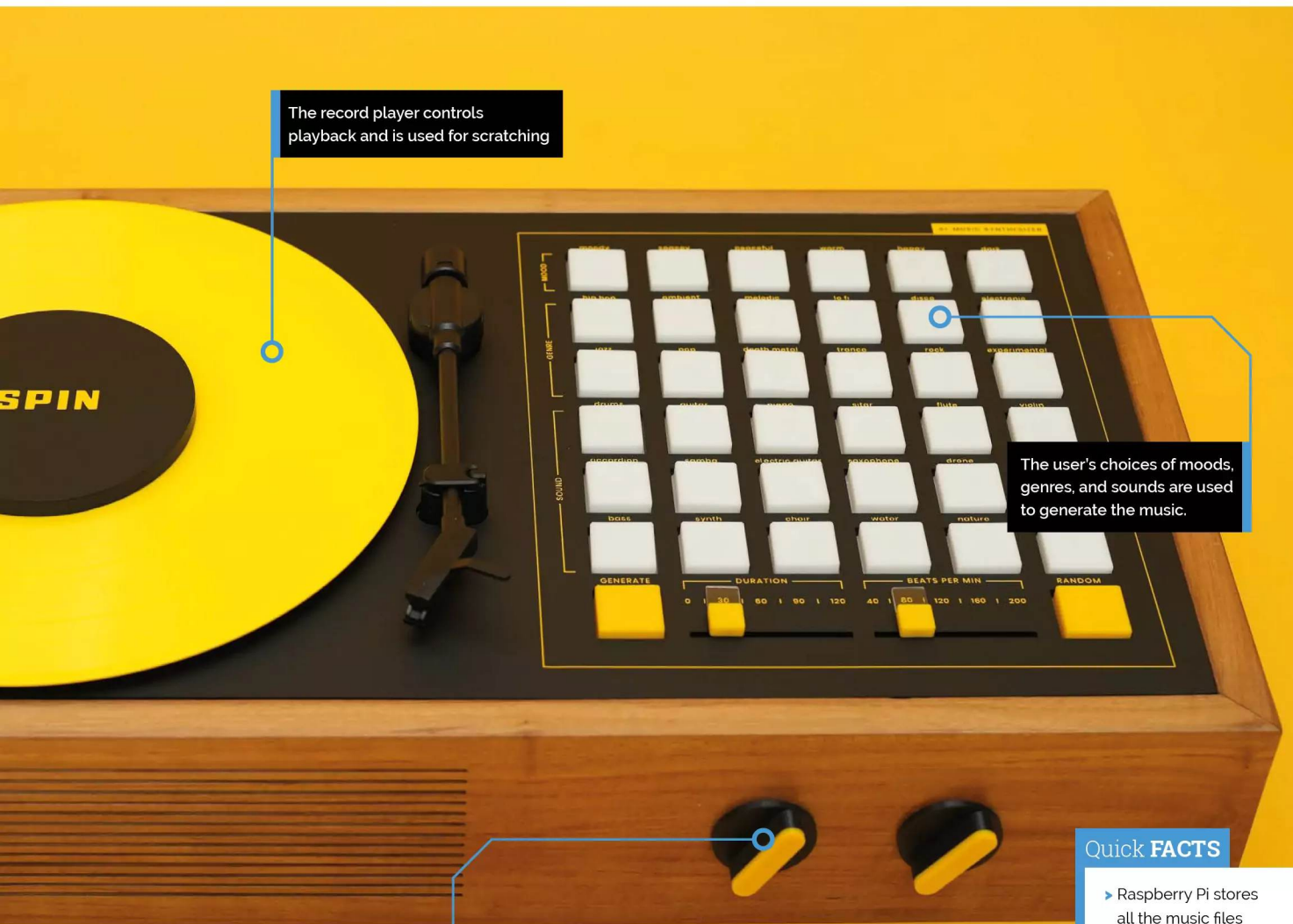

The record player controls playback and is used for scratching

The user's choices of moods, genres, and sounds are used to generate the music.

These knobs control the speaker volume and speed of the record player motor

Quick FACTS

- ▶ Raspberry Pi stores all the music files to revisit later.
- ▶ Meta trained MusicGen with 20,000 hours of licensed music.
- ▶ The record player is a Numark PT-01.
- ▶ The Arduino Mega has 54 digital input/output pins.
- ▶ The project took just under two months, outside work.
- ◀ Raspberry Pi 4 is mounted under the record player. The tiny HDMI screen is shown bottom right.



▼ Arvind removed the record player from its casing so it would fit his cabinet.

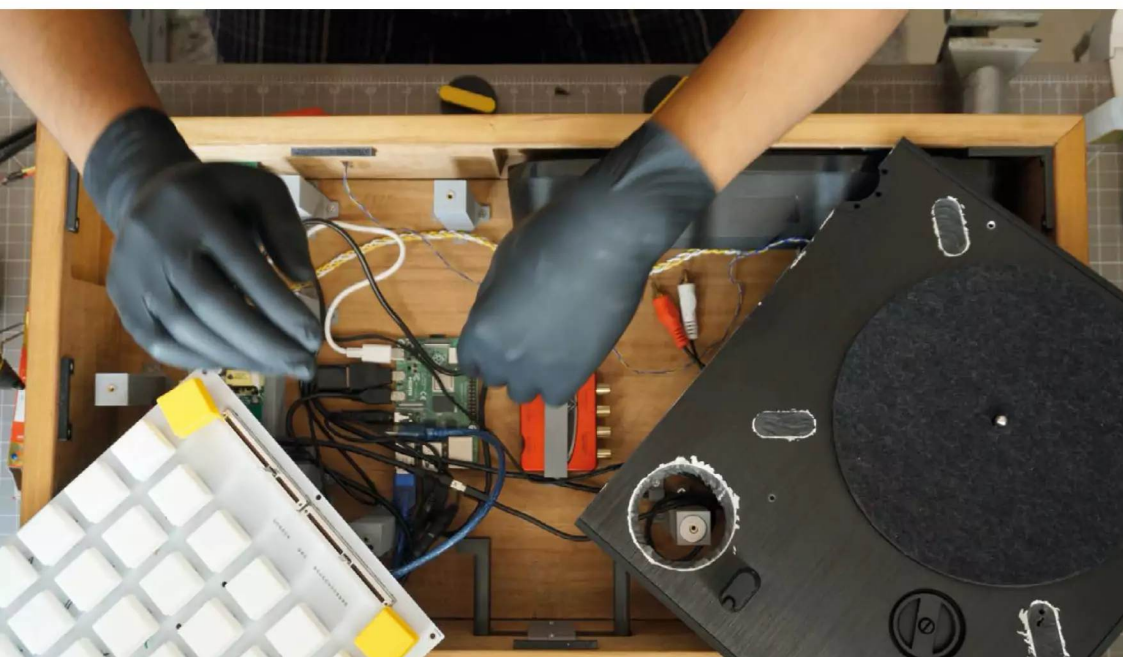

invitation for you to listen to it,” says Arvind, “but in order to listen to it, you need to physically take the needle and put it on the record.” By turning the record backwards and forwards (scratching), you can manipulate the sound.

Leave a light on

Inside the cabinet, Spin houses an Arduino Mega, Raspberry Pi 4, and Behringer audio interface. There is also a speaker and a tiny HDMI screen at the back, connected to Raspberry Pi, to help with debugging.

The buttons have individual NeoPixel LEDs on them (WS2812b) that light up when the button is selected. They’re illuminated in an animated pattern, using the FastLED Arduino library, when the device is switched on, and 3D-printed enclosures act as diffusers for the LEDs.

Arvind prototyped Spin on a breadboard, and then used the open-source design software KiCad to design a printed circuit board (PCB). The PCB was made for him by a company in India.

He chose the Arduino Mega so he could be certain he’d have enough input pins. “I always want a little more freedom,” he says. “I can use extra pins if I want to add something in the future.”

A keyboard matrix library takes the input from the buttons and maps it as if it’s a keyboard. The Arduino creates the text prompt for the AI by combining the words associated with the buttons and the tempo and duration options. The prompt is sent to Raspberry Pi through a serial to USB cable.

Arvind’s Python program on Raspberry Pi sends the prompt to MusicGen, running in the cloud. “At the time, MusicGen was one of the most flexible and creative platforms out there and it sounded relatively good compared to others,” says Arvind. “The other models didn’t have openly accessible application programming interfaces that I could use.”

Spin me right round, baby

To play the music, Spin uses xwax, an open-source digital vinyl system for Linux. This software

enables DJs to control the playback of music files using a normal turntable and a time-coded vinyl record. “It gives them the ability to scratch any music,” says Arvind. “Instead of having music in the grooves, it has timestamps. If you listen to it, it sounds like beeps or a sine wave.”

The signal is sent as audio to a Behringer audio interface, which converts it to digital for Raspberry Pi. Xwax decodes the incoming sound into the timestamps to control the music.

One challenge was that xwax uses a graphical user interface and can't be controlled from the command line. Arvind used a keyboard emulator to simulate the keyboard shortcuts required to load the new track and play it.

The project didn't run entirely smoothly. “It failed at the last point, when everything was in the enclosure, even though I'd been testing in stages,” said Arvind. “I thought it was a software glitch, or it had something to do with the needle not being sensitive enough now because it had been running a long time. I took everything apart, piece by piece, and tested it. There was a loose contact within the audio jack from the record player that I had to resolder.”

“ I took everything apart, piece by piece, and tested it ”

Arvind's had queries from DJs asking if he's selling it, and he's hoping to collaborate with artists in the Bay Area when he relocates to San Francisco shortly. He has no plans to start manufacturing it, though, preferring to do more experiments. “I would be happy to see someone creating their own commercial version,” he says. “That would be a nice thing to see in the world.”

What's his favourite combination? “I love lo-fi tracks,” says Arvind, “so I always start with a combination of peaceful, hip hop, lo-fi and some piano. But death metal orchestra and death metal disco are really fun to try.” 

Taking AI for a spin

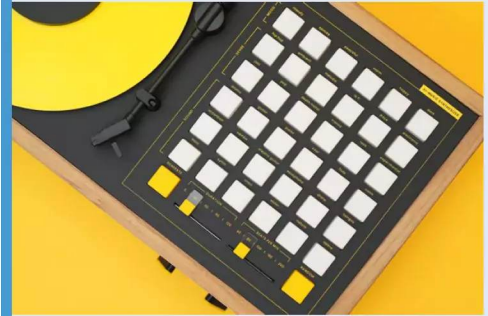

01 The buttons are connected to the Arduino Mega using a keyboard matrix. The Arduino receives your button choices, and turns them into a text prompt for AI.

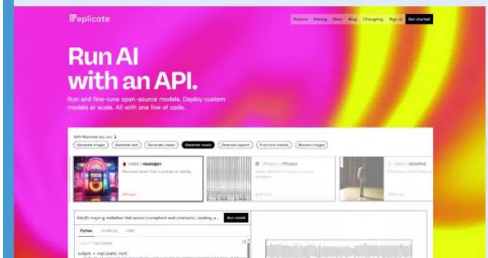

02 Raspberry Pi sends the prompt to the MusicGen AI model, running on **replicate.com**. Raspberry Pi converts the audio from WAV to an MP3, which is played using the xwax digital vinyl system.



03 The signal from the time-coded vinyl is sent as audio, through a Behringer audio interface to the Raspberry Pi. Xwax converts this audio to timecodes and controls the playback.

The Dicemaster 2000

It looks like a game controller but for visually impaired people this dice-rolling device is actually a game changer as **David Crookes** discovers



Christopher Hall

Christopher Hall is a Senior Network Engineer from Pikeville, KY, USA. He's a maker at heart and lover of all things geeky.

magpi.cc/dm2000

Chris Hall enjoys playing board games and he's part of a local gaming group.

He attends with his best friend and the pair have had many happy times but a medical condition affecting his pal's vision has threatened to spoil the fun. "About a year ago, my best friend was diagnosed with a degenerative eye disease," says Chris. "So when his birthday was coming up, I wanted to do something special for him."

Most of the games played by the group involve the rolling of dice and the problem for his friend was all too apparent: without someone reading out the result, he wouldn't know what numbers were showing. The answer, Chris surmised, was a dice-rolling device that his friend could use independently which would read out the results and incorporate some other handy features. "I figured it would help him out and be a surprise gift," he tells us.

From the start, Chris had an idea of what he wanted from the device. "I knew what I wanted to achieve – for my friend to press buttons, for virtual dice to be rolled and the result to be announced," he says. "From there it was just about figuring out which components to use and how to lay them out efficiently. This needed to be hand-held, so a compact design was a must."

To that end, Chris modelled the device on a gamepad. "I tried to imagine a controller, like an Xbox controller," he says. "I sought to work out how it would look, feel and where the thumbs would rest. I wanted to make something that was comfortable and felt familiar and I also needed it to operate without being plugged in so I chose a Raspberry Pi Pico and used an 18650 battery shield to power it along with the other components."

Roll with it

Selecting the Raspberry Pi Pico meant the dice roller could be compact and use minimal power. "It's instantly on and it was able to handle the different components I needed, such as a microSD card reader, an audio amp with speaker and a litany of buttons," Chris says.

Those buttons would be 3D printed with Braille so that his friend would be able to read their various functions and control the device effectively and independently. "Adding Braille wasn't very difficult," Chris says. "I designed flat button caps then added the Braille numbers to them in Blender, the free open-source 3D computer graphics software."

Board games often make use of non-traditional dice – in other words, they're not always familiar cubes with six marked faces. The standard polyhedral dice set also includes those with four, eight, ten, 12 and 20 sides (the entire set being referred to as d4, d6, d8, d10, d12 and d20). "I needed to have a button for each one," Chris says. He also added two extras: Reset and Roll.

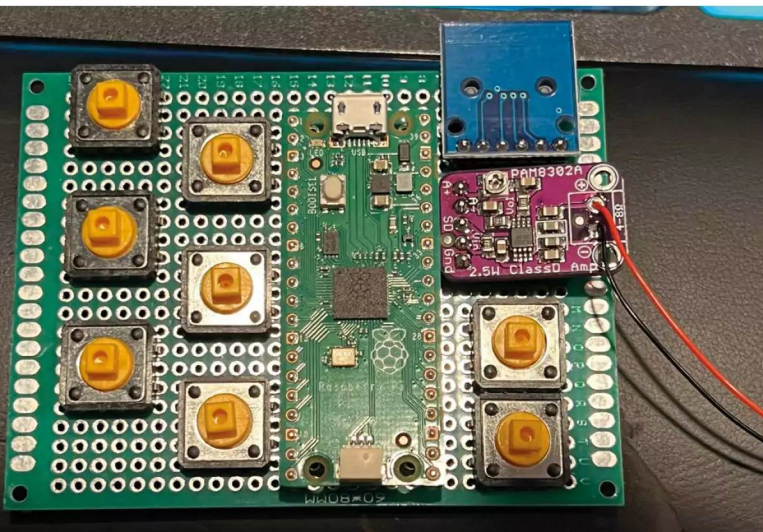

▲ The device makes use of a Raspberry Pi Pico board connected to a protoboard which is wired to the buttons and a PAM8302 2.5 Class D single channel amp

Quick **FACTS**

- ▶ It's a handheld dice-roller for visually impaired people
- ▶ Each of the buttons is imprinted with Braille numbers
- ▶ It can mix and match six different die types
- ▶ Die pools can be saved and loaded
- ▶ There's a power switch to save battery life

Each button to the left represents the six dice in a polyhedral set. Four of them can be long-pressed for extra functions

Dicemaster 2000 doesn't actually mean anything. "I always thought it was funny when people talked about future tech by slapping 2000 in the name," Chris says



To make the device easier to hold, Chris added some grips to the 3D-printed casing. It also makes it look more striking

“ I designed flat button caps then added the Braille numbers to them in Blender ”

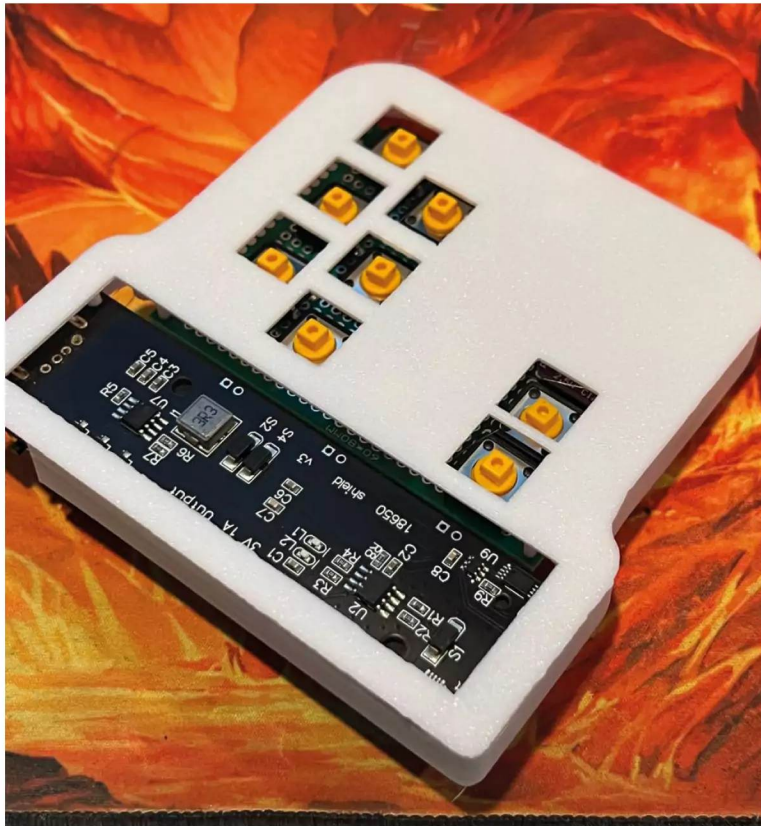

Writing the project in CircuitPython, he created a device that would allow his friend to press one of the numbered buttons to add it to the die pool. When the dice are ready to be rolled, it'd be a case of pressing Roll and listening to the result when it's announced. "In addition, there are some long press modes," Chris adds. "If you hold the d4 button for a few seconds, you will enter quiet mode which plays chimes rather than speaking out every die entered and describing what it's doing. It still announces the results of the roll, but it can cut down on time and I added it in case the normal mode was too distracting to other players at the table."

Holding down d6 saves the current die pool. "This is useful if you're playing something like Dungeons & Dragons and constantly need to roll that big 8d6 fireball [that's eight d6 dice being rolled at once]," Chris continues. "Long-pressing d8 will load the saved die pool from the microSD card, and that means the saved pool will persist across uses." Long-pressing the d10 enters percentage mode which, rather than rolling dice, will simply give a percentage between one and 100.

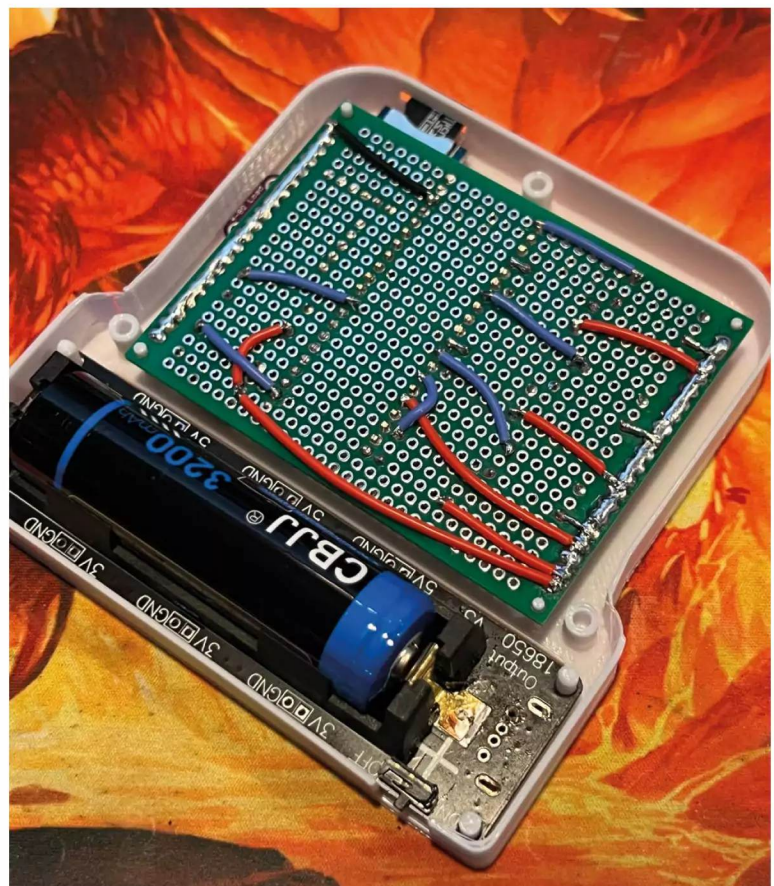

- ▲ The prototype Dicemaster 2000 with its eight buttons and 18650 battery shield
- ▶ As you can see, as well as a rechargeable battery and a lot of soldering, the device is neatly wired



Play the game

Coding all of this was a challenge. “Interfacing with the audio amp was tricky and I wish the device was a bit easier to understand in terms of audio quality, but this may have been due to everything being built on a prototype board,” Chris laments. He also found it difficult to perfect the controller shape. “The housing was 3D printed in a single colour and the top was painted red. I had a good friend of mine help with the ergonomics of it. There was also a lot of soldering,” he adds.

Even so, it’s been worth the time and effort. Chris’ friend loves using the device and he finds it allows him to fully participate in games. It’s also comfortable to hold, easy to use and very effective. What’s more, you can replicate it because Chris has made the code open source and he has also shared the 3D files on Printables (magpi.cc/dm2000files). In that sense, it’s capable of helping many other people with a visual impairment.

Chris is certainly happy overall even though he would have done some things differently. “If there is one part of this project I wish I had done, it would have been to design a custom PCB using something like KiCad – if only I’d had issue 138 of The MagPi [magpi.cc/138] when I started! It probably would have helped a lot with audio issues and made for a cleaner build overall. It’s definitely on my list of things to learn for future projects.” ⁴⁴

▲ The case took some time to perfect, but it’s been designed to be comfortable to hold while giving easy finger access to the buttons

Rolling the dice



01 Users press buttons representing the six types of polyhedral dice (d4, d6, d8, d10, d12 and d20) to add them to the dice pool. Dicemaster 2000 will hold a pool of up to 20 dice, either all the same type or a mixture.



02 Once the correct number and type of dice have been added, the user presses the Roll button. The result is verbally announced via the built-in speaker. If Roll is pressed again, the result will be repeated. Reset empties the pool.



03 The different modes make life even easier. A die pool can be saved and loaded to a microSD card which is inserted in the top of the device. The device can be made to talk less by long-pressing d4 to make use of chimes instead.

Colour Word Clock

The GurgleApps siblings return to their roots with this fun and practical word clock kit. **Rob Zwetsloot** spends some time with it.



Gurgle Apps has been making fun electronics projects (and tutorial!) videos for years now, and we've included what they've made in the mag several times. The three siblings Amelia, Caleb and Zivya are back again in these pages with a kit that you can actually build yourself – the Colour Word Clock.

“One of our first ever projects was a tiny 8x8 LED matrix word clock using a Raspberry Pi,” the siblings explain to us. “At that time we were too young to do it on our own, our Dad made it to teach us a bit of Python and electronics. We remember making little pictures on an 8x8 grid on paper then turning it into binary then hex to get it to display on the LED matrix.”

You can still see the video on their channel: magpi.cc/gurgleapps.

“We wanted to make some kind of kit for people to build and hack and remembered that fun little project,” they continue. “[It] can be controlled via a web interface on any device connected to the same network. The clock displays the time in words and has a variety of display modes... It was important to us that the code was open source and the kit was easy to build and modify. The kit is aimed at beginners and experienced makers alike. It was also important to us that the kit was affordable, and if you don't want to buy the kit you can build it yourself using the open-source code and easy-to-source components, and 3D-print the case. All the case files are open source and free to download.”

MAKER GurgleApps

Amelia, Caleb, and Zivya are the three-person team of GurgleApps, a STEM YouTube channel focusing on electronics that has been going for years. They're also siblings.

magpi.cc/colwordclock

► The completed kit, ready to tell the time



LEDs light up the words
so you can read the time

The black fascia
gives the project a
professional look

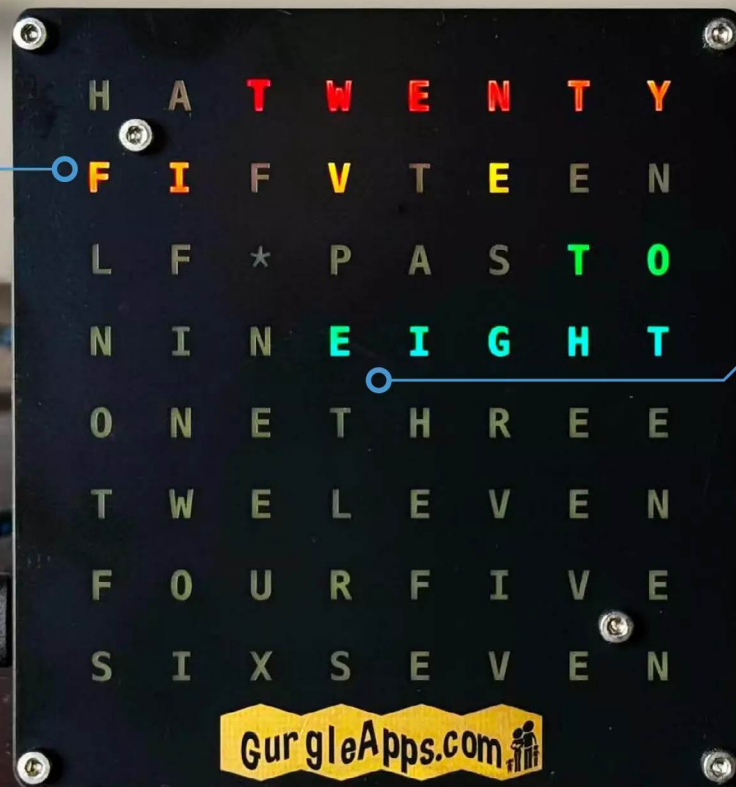

Quick FACTS

- ▶ This is not their first product – that was the Raspberry Pi Pico Pinout Coaster
- ▶ You can still get the code for the original LED matrix used
- ▶ There's a limited run of white face plates for the clock
- ▶ The code is being updated with features added by the community
- ▶ They admit to treating their Picos pretty roughly, but they always keep working

▶ The white version was requested by viewers

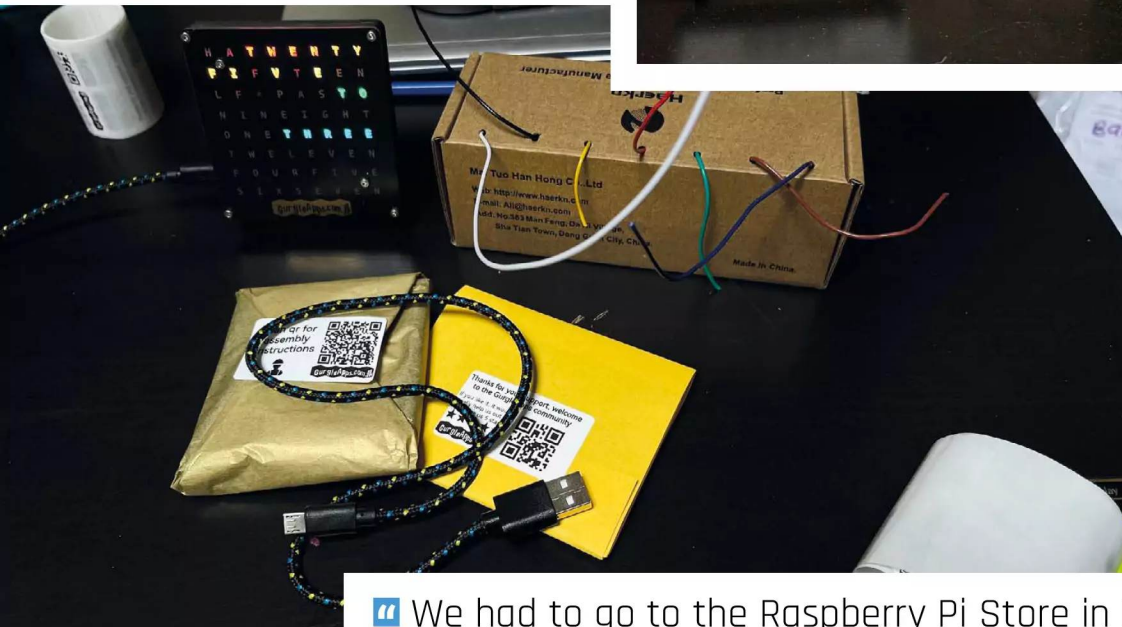
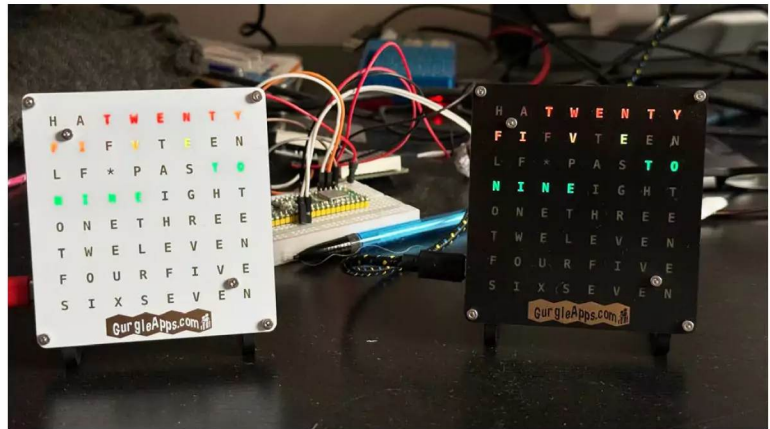

▲ The kit is compact but comes with everything you need for the build

“ We had to go to the Raspberry Pi Store in Leeds to get more Picos and had both 3D printers running pretty much constantly to get more kits made ”



Warning!
Hot solder

Soldering irons get very hot, and stay hot for a long time after they're unplugged. Make sure that you put the iron in the stand when you're not using it and don't touch the metal parts – even after it's unplugged.

magpi.cc/soldering

Reliable Pico

The wireless capabilities of the project were extremely important to the siblings.

“We'd just open-sourced a MicroPython Web Server (magpi.cc/mpwebservice) to control projects using a browser, and thought it would really show off what it could do,” they say.

Despite their love of Raspberry Pi Pico (“we usually use Raspberry Pi Pico unless there is a specific reason to use something else,”) they began experimenting with another microcontroller, however it just couldn't hack it.

“We found the Wi-Fi connection degraded when we left it running for a few days, we went through four different [microcontrollers] and they all had the same issue,” they explain. “At this stage the clock was still a tiny 8x8 LED matrix word clock which used I2C and SPI, and we also had intermittent issues

with the I2C connection. We have so many Raspberry Pi Picos lying around that we decided to try one of those and it was bulletproof from the start.”

Like a lot of products, the clock went through many design changes – as you may have noticed, it definitely doesn't ship with a tiny 8x8 LED matrix.

“If you've seen any of our videos you'll see projects stuck together with Blu Tack and gaffer tape, but you can't do that with a product you're going to sell,” they admit. “We went through hundreds of different designs and prototypes. The 3D-printed faceplate alone we tried with dozens of different fonts, sizes and colours. Dropping the small 8x8 LED matrix was a big decision, we had to start again with the code and the faceplate. We had to make the clock bigger to fit the larger LED matrix and completely redesign the case but it started to come together and look like a product we'd be proud to sell.”

Rave reviews

Like Raspberry Pi itself, GurgleApps had modest expectations for the Word Clock – and they were completely smashed.

“We only had 10 kits and they sold out immediately,” they say. “We had to go to the Raspberry Pi Store in Leeds to get more Picos and had both 3D printers running pretty much constantly to get more kits made.

“What we are most pleased about though are the comments and support from people who have bought the kit. We’ve been astounded by the way it has been hacked and modified by people who have bought it. A teacher sent us a photo of him using it in class to teach English. Pretty quickly we’d seen the clock doing things we’d never thought of. The ingenuity of the people who have bought the kit has been amazing. We’ve had something new to show every week on our Sunday live streams and get to chat to the people who have built their clocks.”

Rob has one ready to build for his office desk, a topic you may remember causing him some concern in a previous issue’s Final Word. We hope they make their way to desks around the world. [M](#)

▼ The complete Word Clock is a great looking accessory to your techy desk



Layers of fun

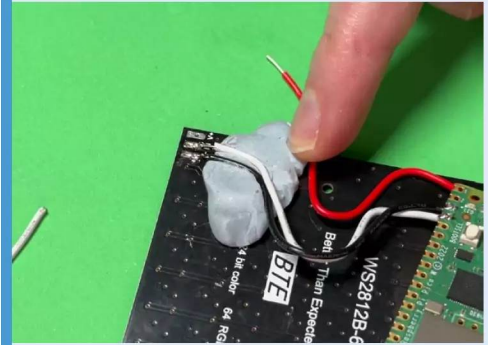

- 01** You'll need to solder the correct wires to Raspberry Pi Pico and then to the LED board – there's only three to worry about though.



- 02** Much like a Pimoroni PiBow, you assemble the case up in layers, starting with the faceplate with the words on.



- 03** Add the backplate to secure Pico and you're ready to go – you'll just need to add the software and turn it on.

Puttr

Getting good at golf without the green fees with a bit of help from Raspberry Pi? **Rosie Hattersley** wants to know more



Matthew Allard

MAKER

Puttr CEO Matthew has worked on mobile software and for AOL on smart home development. This is his first Raspberry Pi project.

puttr.co

Executive boardrooms up and down the land are (according to urban myth or business tropes) stuffed to their expensive gills with bag after bag of golf clubs; their owners while away the working week so they can head off to the fairway and execute some impressive swings and putts.

What joy to learn of a miniature putting mat that puts those otherwise idle clubs to good use mid-week too. Puttr (puttr.co) makes excellent use of Raspberry Pi 4 and an HQ Camera to determine whether a putt is made or missed, logging results on a linked app.

Like many great ideas, Puttr came about because of some enforced downtime during lockdown. Entrepreneur and founder of several successful start-ups Matthew Allard had been on the golf team at university, and lockdown had him contemplating an at-home putting game that he and his son could both enjoy. Matthew had a personal interest in how software and computers can interact with the real world, and having taken post-graduate courses in embedded systems was keen to make use of what he'd learned.

One thing Matthew knew already was that "putting practice is boring and lonely" (don't they have crazy golf courses in the US?) yet it accounts for 42% of time golfers put in. Creating a means to connect fellow golfers and 'gamify' putting could transform this rote activity and allow members of the golfing community to challenge each other with online tournaments.

Hits and misses

Matthew originally aimed to track made and missed putts via an app using sensors in the hole of an at-home putting mat hooked up to GPIO pins. However,



▶ The 3D printed and injection moulded case doubles as a storage case

Quick **FACTS**

- ▶ The hole in a golf course is only 2.5x the diameter of the ball
- ▶ Off-course golfing exceeds on-course golfing
- ▶ Adjustable legs help ensure the playmat is fully flat
- ▶ While Raspberry Pi's camera provides a visual confirmation...
- ▶ ...then automatically connects putting mat to phone via Bluetooth

A perfectly flat putting mat is vital: the camera comes in useful again here, lighting up an LED when alignment is just right

Puttr uses Raspberry Pi 4 and a wide-angle camera to detect 'made and missed' putts, gamifying an otherwise repetitive aspect of golf practice

Shots can be taken from different places on the 11-foot putting mat, with results logged to the Puttr app and optionally shared with followers

he soon discovered this approach was limited: “I could detect when a ball went in the hole, [but] I couldn’t detect missed putts.” Next, Matthew tried break-beam IR sensors to get more precision and measure missed putts, as well as ‘makes’, but “quickly realised that any sun exposure would cause false positives in the break-beam”.

A friend tipped him off about Raspberry Pi, and Matthew soon saw he could use computer vision and a wide-angle lens to detect the location of the physical hole, then track any golf ball that passed its field of view. Once a ball has entered or exited, it sends the full ball path data over Bluetooth to a connected app on an iOS or Android device, he explains. Details of each putt are logged, with the

user able to access stats on their performance and optionally share it with other Puttr users.

Raspberry Pi quickly proved a great choice, since it offered an operating system with all the tools he needed for the software along with good value hardware that worked well together. “Many suppliers tried to talk me into creating my own board [but] there were many reasons to use Raspberry Pi.” The camera connection, Bluetooth, Wi-Fi, and processor were all included. Matthew was also encouraged by the strong community keen to help with any troubleshooting he might need, given this was his first ever Raspberry Pi project.

▼ Putts can be attempted from multiple distances with balls returned down a chute



Embrace the light

At first, Matthew stuck with his infrared break-beam idea, testing it in his garage in the evenings after long days at his day job. There were “a ton of tweaks” to get the computer vision to work well under different lighting conditions. Eventually, it seemed as though the beams were working just as he expected. “I would get a break when the ball enters the ramp, and another one when and if it entered the hole. Perfect!”

Replicating results when demonstrating the embryonic Puttr game to his son was less successful. In fact, it didn’t work at all in daylight. Matthew eventually realised that sunlight hitting the beam’s receiver was preventing the circuit being broken even when a ball passed through

► Putting mat and chute roll up and are stored in the self-contained Puttr box



it because it emits infrared rays of its own: “Apparently I missed that in school!” Connecting Raspberry Pi 4 to a GATT server (for Apple devices) as a headless Bluetooth peripheral meant code pairing was not an option. Instead, Matthew created a Bluetooth Write Characteristic that can receive a Wi-Fi SSID and password specifically for the task. He then wrote all the computer vision code and app software to make Puttr work.

“ The Puttr app has logged more than a million putts ”

Prototyping involved laser-cutting Baltic birchwood, and Matthew’s first foray into 3D design and printing using CraftCloud to create the box used as both ball tracker and holdall, the ramp, and ball return chute. The clever design is portable, with the mat rolling up inside.

Matthew praises the “stable, tested OS, camera interface, Bluetooth and Wi-Fi, and says choosing Raspberry Pi meant R&D took at least a year less than choosing a different setup with costs that would have been much higher. New versions and applications are already planned. Since launching 18 months ago (after a successful Indigogo crowdfunder), the Puttr app has logged more than a million putts. The clever take on pitch and putts now has worldwide league tables, games and challenges, with a subscription model for golfers keen to pit their skills against others. ”

▼ The Raspberry Pi camera tracks the golf ball as it approaches the hole, logging whether it is putted

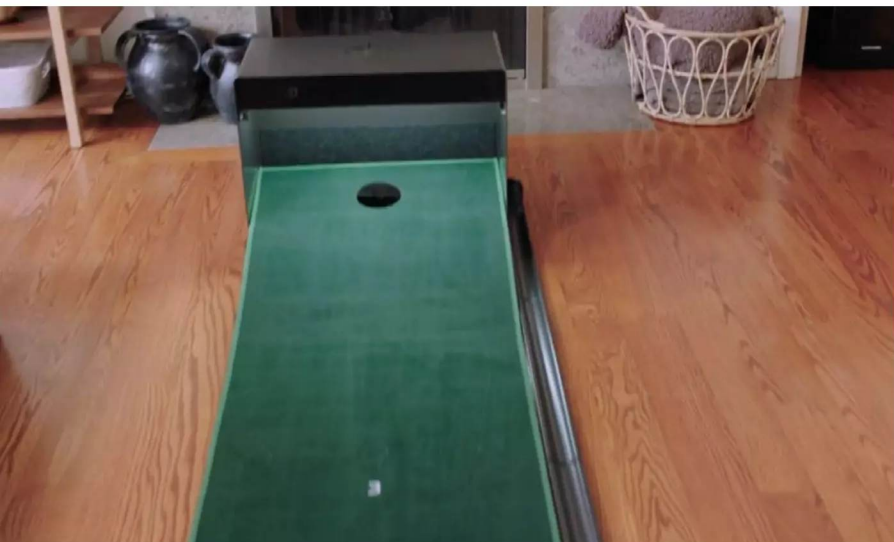

Pitch for perfection

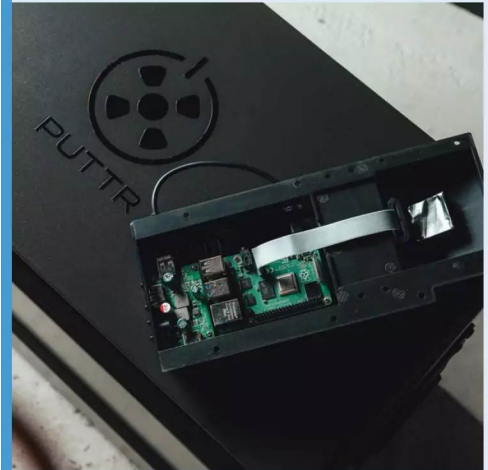

01 Creating a putt-tracker involves mounting Raspberry Pi 4, an infrared lens and wide-angle camera lens in a case (Puttr’s was injection-moulded). Custom computer vision code for Raspbian Buster Lite OS discerns successful putts.

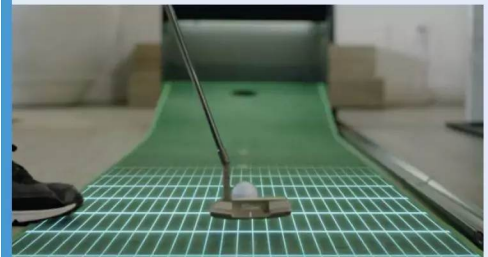

02 The box also contains a printed circuit board and a USB LED light placed above the golf hole, plus a break-beam laser mechanism triggered by the golf ball rolling into the hole or running wide.

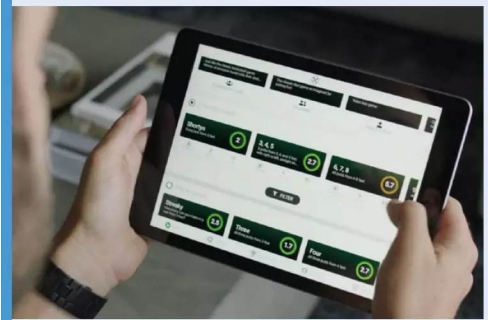

03 The Puttr app automatically connects the mat to the phone or tablet via Bluetooth and records statistics for each player’s putting average.

MathGPT

A fun way to learn maths, powered by Raspberry Pi and AI. **Rob Zwetsloot** sees if it adds up

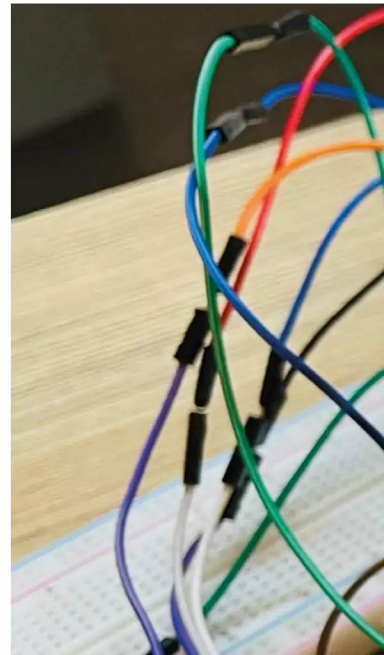

Divya Chandana

A Texan senior software developer who also loves to collect rocks and crystals, build LEGO, and explore technology

magpi.cc/mathgpt

The uses of LLMs with Raspberry Pi have been quite staggering – many of which we’ve covered here in the magazine.

From recipe bots to interactive story tellers, and compliment givers to fortune tellers, the uses seem endless. Maker Divya Chandana has brought us a new one: an educational toy that helps children learn maths.

“Unlike traditional math exercises, this interactive game transforms equations into relatable scenarios, such as ‘two candies + three candies,’ and can dynamically change objects with each question to maintain engagement and curiosity,” Divya tells us. “The game utilises ChatGPT to generate questions, seamlessly adjusting difficulty as children progress in the game and featuring arithmetic operations including addition, subtraction and multiplication.”

It’s built in a fun LEGO facade, with LEDs letting you know if your answer was correct or not. This provides immediate feedback ‘without punitive scoring’ says Divya, and allows kids to keep trying until they succeed.

“As children conquer level one with all correct answers, they unlock subsequent levels for continuous learning and enjoyment, devoid of penalties or restrictions,” Divya explains. “The idea started when I noticed my neighbour’s kid having a tough time with maths, especially with numbers. When I switched the questions to use objects instead of just numbers, like talking about apples

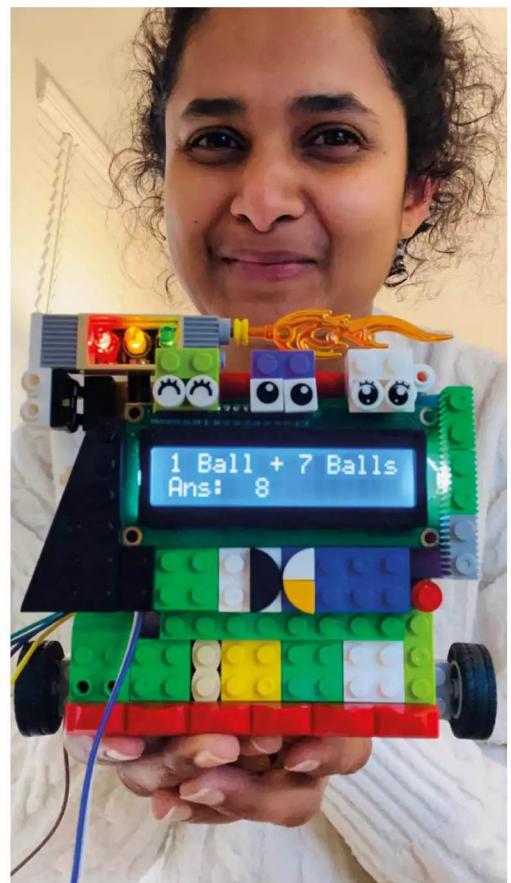

▶ Divya with her creation – it’s not quite all enclosed yet

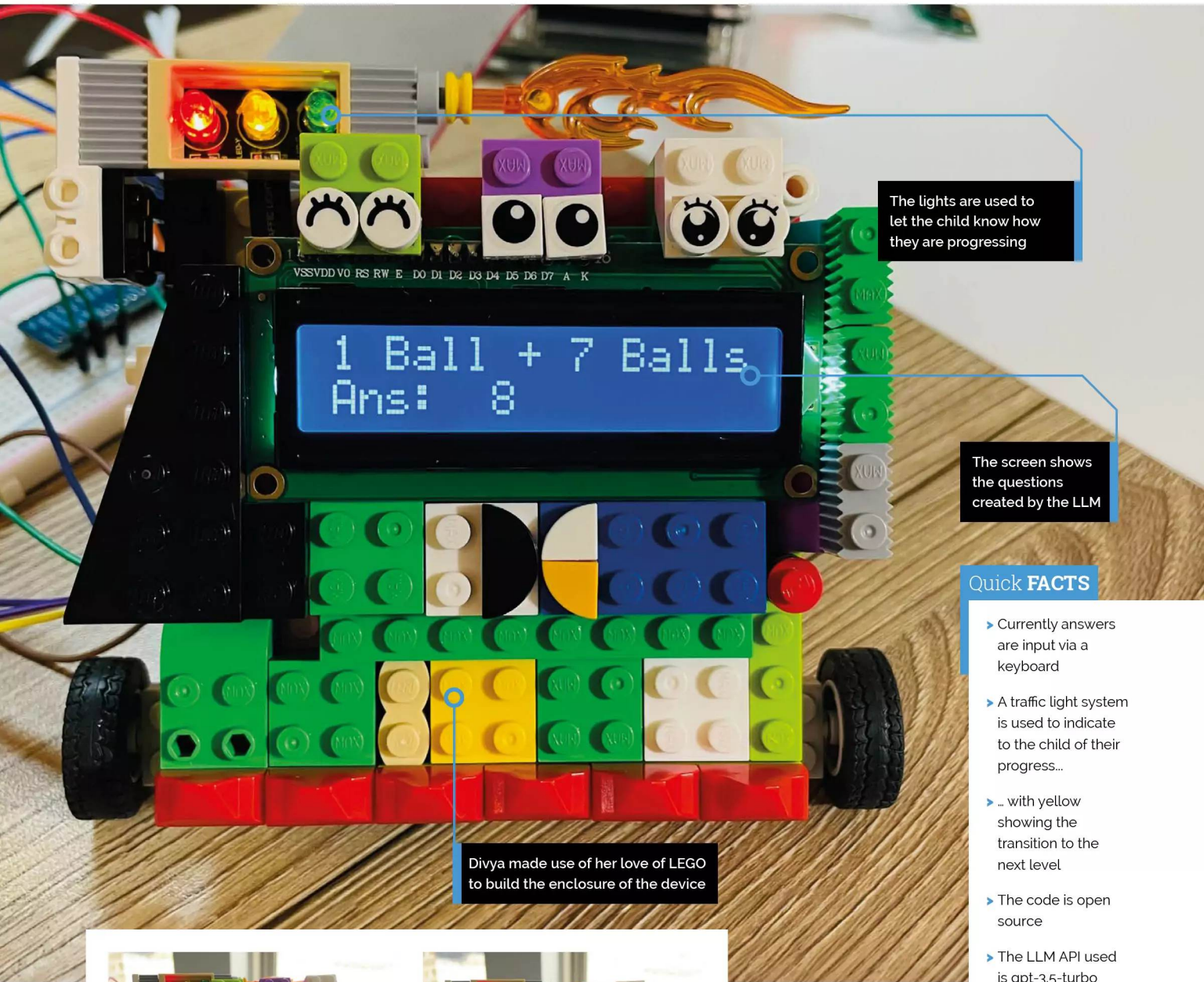

The lights are used to let the child know how they are progressing

The screen shows the questions created by the LLM

Divya made use of her love of LEGO to build the enclosure of the device

Quick FACTS

- ▶ Currently answers are input via a keyboard
- ▶ A traffic light system is used to indicate to the child of their progress...
- ▶ ... with yellow showing the transition to the next level
- ▶ The code is open source
- ▶ The LLM API used is gpt-3.5-turbo

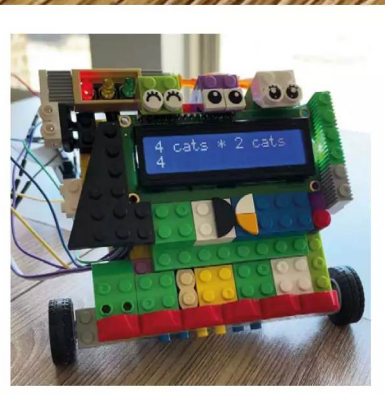
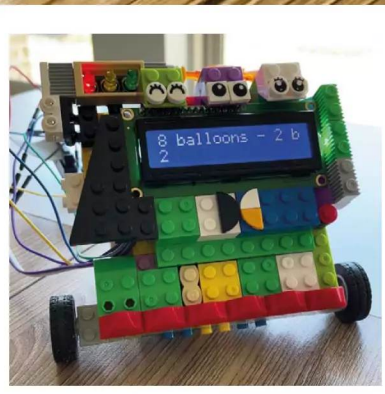

- ◀ Even if you get the answer wrong, you can try again - it's a non-punitive scoring system as well
- ◀ Multiplications are also included for slightly more advanced questions

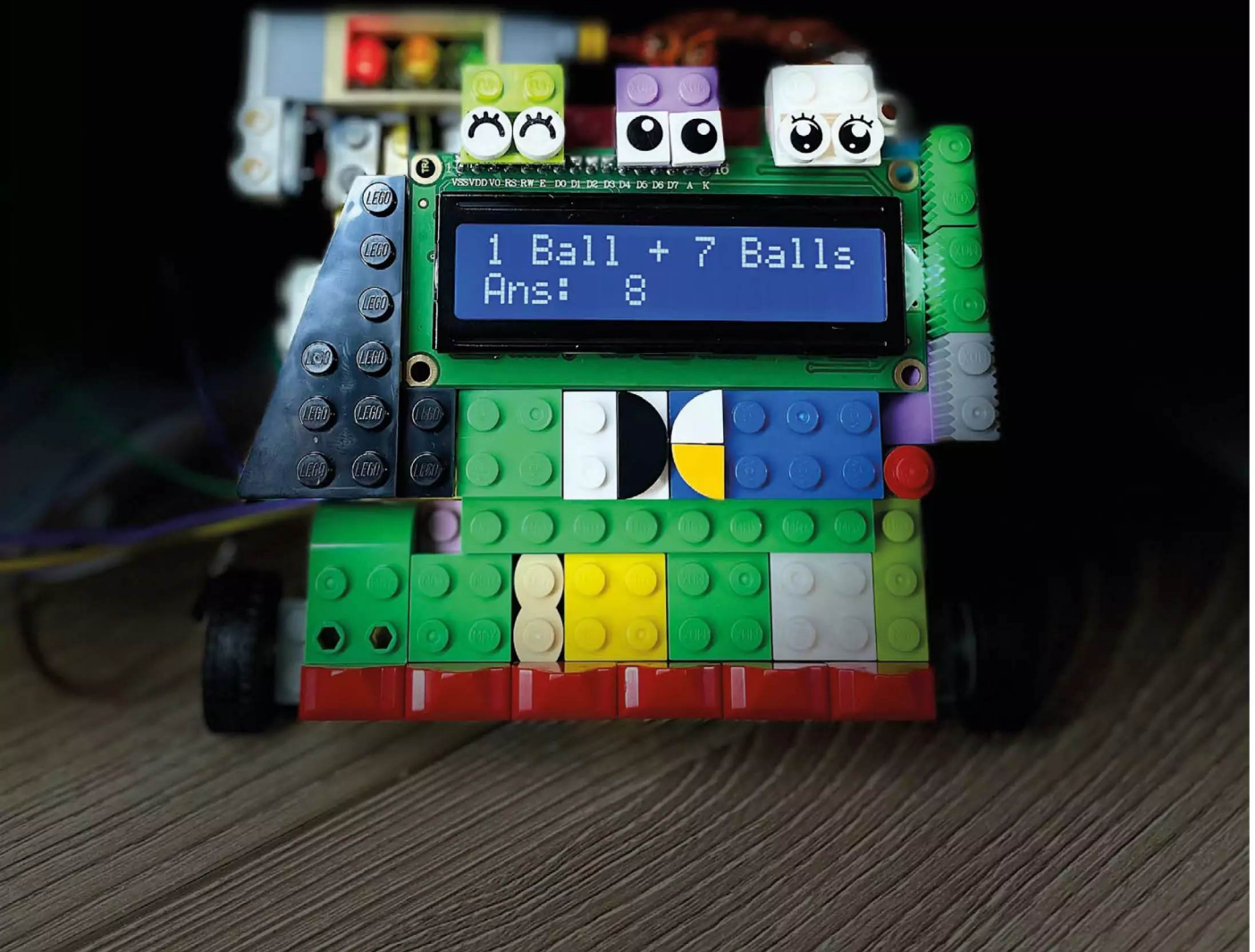

“ Raspberry Pi also makes integrating ChatGPT straightforward, allowing for the use of AI technology without complications ”

or toys, it was like [a switch turned on]. Suddenly, they could picture it in their mind and come up with the answers. It made me see how this kind of approach could help with visual, verbal, and logical thinking. I thought if one kid was struggling, there might be others facing the same issue. So, I decided to create a fun and engaging way to learn maths, using what I had learned to help kids grasp the concepts more naturally.”

Wrangling an AI

Divya broke down the build process into multiple parts: conceptualising and design, game mechanics, software and AI integration, choosing the hardware, programming, and testing. With the concept and game mechanics already sorted, she began designing the prompts to be used. “Designing the prompts for the OpenAI API was crucial,” Divya tells us. “The prompts needed to be carefully crafted to generate questions that are age-appropriate, engaging, and varied in difficulty.”

Raspberry Pi became the computer of choice for the project after this initial development.

“I chose Raspberry Pi 4 for this project because it’s affordable and portable, making it an excellent option for a setup that can be easily moved around,” Divya explains. “Raspberry Pi also makes integrating ChatGPT straightforward, allowing for the use of AI technology without complications. Plus, it’s simple to connect hardware like the LCD display and LED lights to Raspberry Pi.”

After testing and refining her program, she built the very striking LEGO enclosure. “This hands-on approach not only protected the electronics but also added a playful, tactile element to the project,” Divya says.

Next steps

The project works perfectly in its current form, with Divya quite proud of how the user interface is easy to use. She’s not done yet though.

“The next iteration, MathGPT2, aims to introduce story-based math problems,” Divya says. “This approach will make learning even more engaging by weaving arithmetic operations into compelling narratives, allowing children to solve math problems within the context of stories.”

She also plans to add multilingual support, and even voice support starting with text-to-speech and maybe moving onto voice input too. [M](#)

▶ With Math GPT on wheels it looks like it truly is portable, like Raspberry Pi

A game of maths



01 Turn it on and Math GPT greets you, ready to start giving you questions. Input is currently made via a keyboard.

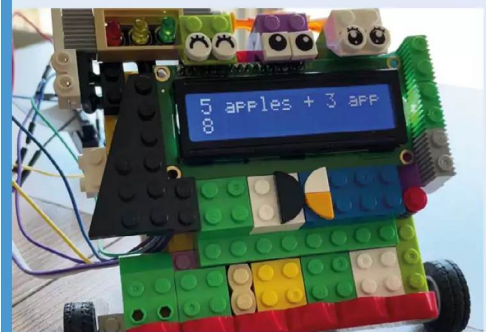

02 Correct answers to the questions posed via ChatGPT light a green LED to let you know you’re going on to the next question. Wrong answers result in a red, but you’re allowed to keep trying.



03 At the end of the level, your score is tallied and you go onto the next level. Questions become harder, yet are still suitable for children.

Retro gaming magic mirror

David Edwards' magic mirror gives information about the present and future while also providing a blast from the past, reflects **David Crookes**



David Edwards

David Edwards has been tinkering with electronics from a young age and he presents insightful videos for Element14.

magpi.cc/retromirror

Many hobbyists have used Raspberry Pi to create a magic mirror or a retro games console. But, as David Edwards has shown, it's possible to do both at the same time, taking the concept of a magic mirror and a console to a whole new, playful level.

"I have long wanted to build a magic mirror," David says. "It's a great way to access common information that would otherwise be locked on a smartphone. I have also liked wall-hanging small arcade machines, but I have neither the space or permission to install one! The solution, for me, was to combine both concepts into one device."

With that in mind, he went big. And we mean really big. He took a 65-inch touchscreen and connected it to a Raspberry Pi 5 computer, figuring games would look amazing across such a large display. It also enabled David to create a full-length mirror, despite it posing issues of its own.

"Working with such a large display was a challenge due to the physical weight of moving and manipulating it," he explains. "I think it weighed 48kg so I really shouldn't have been lifting it on my own. I was afraid I would break it by letting it flex, cracking the screen."

Looking good

Initially, David tested the concept using a Raspberry Pi 3 computer and an official Raspberry Pi seven-inch touchscreen. He played around with PINN, a version of the NOOBS operating system installer, and sought to get everything working with RetroPie before ordering the larger equipment.

"Unfortunately, the curse of the early adopter struck, with RetroPie and PINN not having official support for Raspberry Pi 5 at the time," David says. "It took some time to get PINN working at all and, even then, I think Raspberry Pi 5 support was questionable." David switched to Recalbox which was installed on one partition. Another partition was used for the magic mirror functions.

"I wanted the mirror to play as many gaming platforms as possible"



▲ With no information being displayed nor any game being played, the device is a simple, full-length mirror

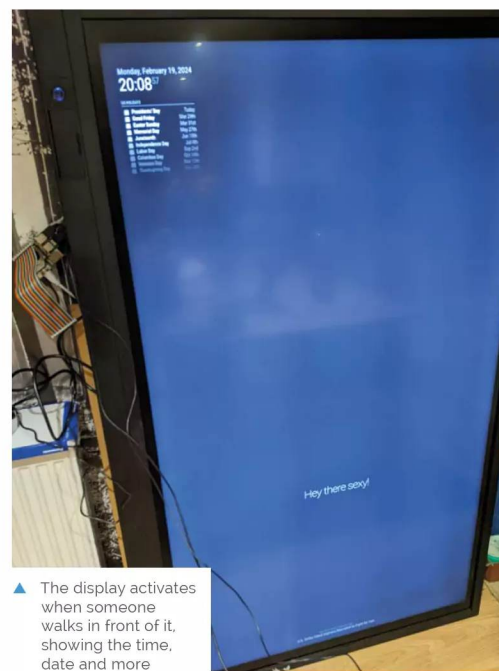

▲ The display activates when someone walks in front of it, showing the time, date and more

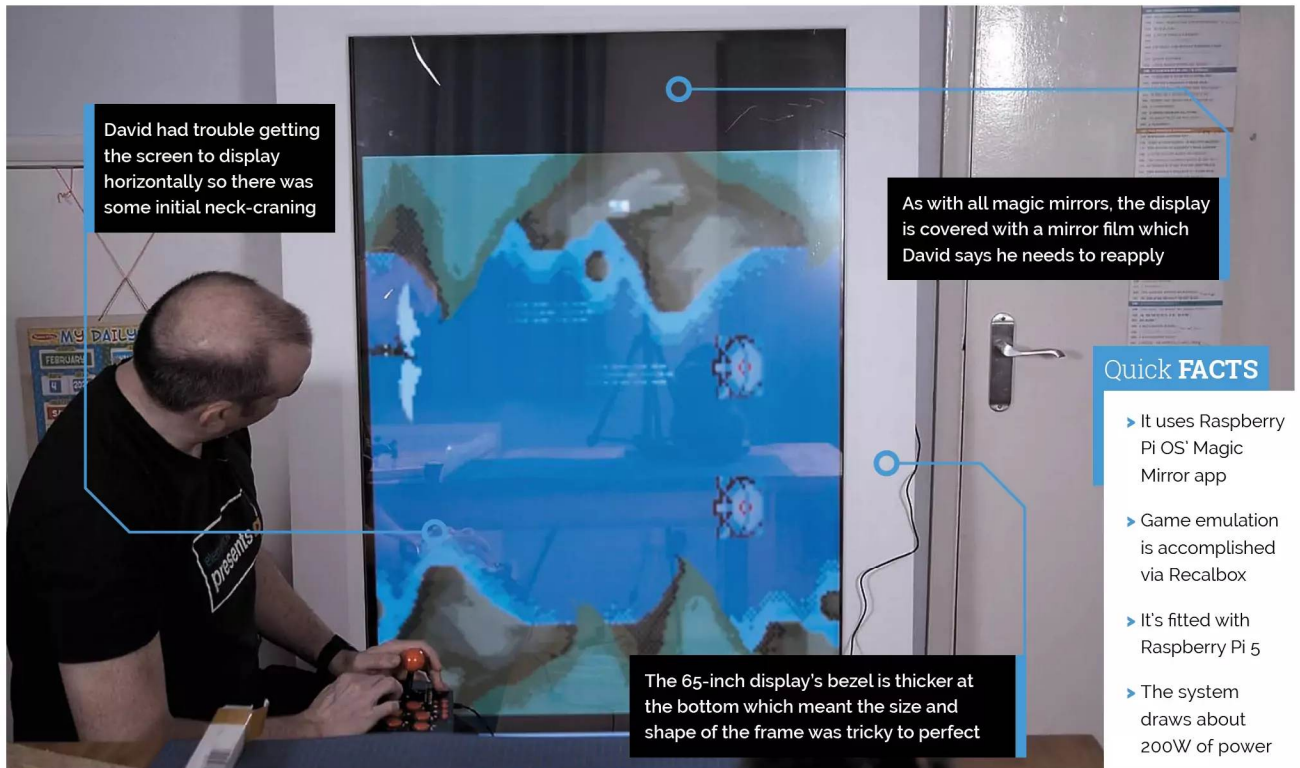
**Quick FACTS**

- ▶ It uses Raspberry Pi OS' Magic Mirror app
- ▶ Game emulation is accomplished via Recalbox
- ▶ It's fitted with Raspberry Pi 5
- ▶ The system draws about 200W of power
- ▶ So it only activates when someone is close by



"I wanted the mirror to play as many gaming platforms as possible," David says. "To achieve this I figured I needed the most processing power, and the Raspberry Pi 5 seemed the best way to go. So far it has proved more than capable of emulating games on many platforms without much trouble."

On reflection

David also added motion-sensing using a PIR sensor. When someone walks in front of the sensor, the screen turns on. When the person moves away, it turns off. The display also turns off at night and comes back on in the morning, using the Raspberry Pi OS' Magic Mirror app to show the weather forecast, a calendar and more. The build also includes an RS232 converter so that the Raspberry Pi's Universal Asynchronous Receiver/Transmitter (UART) can be converted for serial communications.

When you want to play, controllers can be connected via Bluetooth Low-Energy or USB, and the games look a treat on such a large screen. There is still room for improvement, however. "I still need to get around to reapplying the mirror film again," he says. "I'd also like to spend more time with the plugins to the magic mirror platform, maybe even develop a couple of my own to make the best use of the screen real estate available. Maybe in the future there is scope for a camera, facial recognition and a multi-user experience." **M**

- ◀ When assembled, the magic mirror dual boots between Raspberry Pi OS and Recalbox

SUCCESS STORY magpi.cc/success

Homey Pro smart home hub

An advanced hub that makes smart home systems smarter, more customisable, and easier to control. By Phil King

Powered by Raspberry Pi Compute Module 4, Homey Pro (homey.app) gives users a single interface to control and monitor all their smart home devices from different brands. It does everything on the local network, not in the cloud, for the lowest latency, highest reliability, and strictest privacy.

Athom was co-founded in 2014 by Emile Nijssen and Stefan Witkamp in The Netherlands, launching its first Homey device, a smart speaker/home hub, via a Kickstarter campaign. Since then, the company has released a series of Homey models with ever-increasing processing power and more advanced feature sets.

The latest in the line is the new-generation Homey Pro smart home hub, based around Raspberry Pi Compute Module 4. Designed to be compatible with “practically all” smart devices, it’s packed with modules and antennas to support a wide range of communications protocols.

Homey Pro enables users to control their entire smart home from one place with a smartphone app or web dashboard. Home automations can also be programmed via an easy-to-use card-based ‘Flow’ system, with no coding knowledge required. A large community of users share their Flow creations with others, and even publish apps to the Homey App Store.

▼ The Homey Pro Smart Home Hub

“ Homey Pro has a wide target audience: anyone with smart devices who wants to automate their home ”



The challenge

“With Homey Pro we really wanted to make the world’s most advanced smart home hub,” says co-founder and creative director Emile Nijssen. “We always try to strike a balance between user-friendliness and polished design... but also very advanced software. So our customers can go really deep and customise many things, but still without sacrificing usability. That’s the main reason our customers choose Homey instead of open-source projects or limited stuff like big tech delivers. They want the best of both worlds.”

The new-generation Homey Pro was in development for over two years and is built upon the architecture of Homey Bridge, released in 2022 to add local wireless connectivity to earlier Homey models. To work with the widest possible range of devices, it supports numerous communications systems, including Zigbee,



◀ Raspberry Pi Compute Module 4 inside the Homey Pro

Z-Wave, Wi-Fi, Bluetooth, 433MHz RF, infrared, and Thread.

One challenge was to fit all the necessary antennas and modules into the device. “We didn’t want it to look like a gaming router with all these antennas sticking out,” says Emile. “So getting that right took a long time. And we also wanted to profit from the development that we did on Homey Bridge. So actually while designing Homey Bridge, which is sort of a light version of Homey Pro, even if you look at it from the outside, we already were thinking about how we could put our own carrier board on top of it that could carry, for example, a Compute Module.” Doing this would offer a way to support all the communications modules that were needed, while providing a mature software environment that would help the team build a rich and frictionless user experience.

The solution

“At the point in time when we were designing, the Compute Module was a perfect candidate for what we wanted to do because the time to market is faster,” recalls Emile. “We didn’t have to reinvent the wheel to build a small Linux computer.”

Instead, the team was able to focus specifically on the excellent smart home functionality they aimed to offer.

Integrating Raspberry Pi Compute Module 4 into the design was straightforward, he says. “It’s well documented. The software is readily available. And that’s something I’m very proud of: we did really build on the booting software so that the Pi turns into USB mode so you can flash it with software. And we built this beautiful website around it so you can actually flash your Homey Pro within the browser.”

Most of the other electronics within the device are communication modules. “We have Zigbee and Thread. They share a radio, and we have a Z-Wave chip, and we have a 433MHz modem from Texas Instruments.” There’s also an infrared LED to transmit IR data, along with an RGB LED ring to give feedback to the user. Everything is connected to a Raspberry Pi Compute Module 4, which also controls an ESP32 board to talk to some other peripherals.

Why Raspberry Pi?

“I’ve always had my eyes on Raspberry Pi from the beginning,” reveals Emile. “So finally when the Compute Module 4 with Wi-Fi and Bluetooth was announced, we jumped immediately on it. I think like one day after the announcement I called my electrical engineers and said, you have to throw everything you did in the trash and we’re switching to this right now.”

He says the main advantage of using Raspberry Pi is the software support. “I mean there are a lot of Linux boards out there, but they come with a ‘build your own device tree’ kind of vibe. So the Raspberry Pi community is amazing. There’s a lot of stuff already done before you. For the Compute Module itself, it strikes a pretty good balance between functionality, form factor and cost.”



◀ The Homey Pro Insights Dashboard

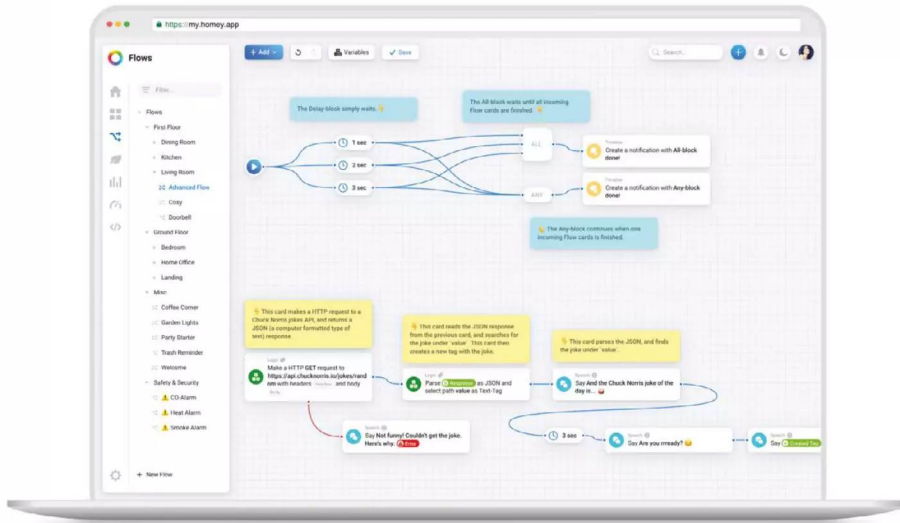

- ◀ Creating advanced flows in the Homey Pro web app
- ▶ Controlling devices from Homey Pro's smartphone app

The results

Homey Pro has a wide target audience: anyone with smart devices who wants to automate their home, but doesn't want to spend too much time setting it up. "They want something that works out of the box and then they can start to play with it and go from there," explains Emile. "I'd like to call them nerds with taste. So people who just enjoy a great product that's polished, that has a lot of love in it." It also makes it easier to use a wide range of smart devices without the need to resort to multiple smartphone apps: "That's where Homey comes in to make a great experience by bundling those devices."

Emile notes that it's easier to set up and use than an open source solution such as Home Assistant, saying that users "switch to something like Homey Pro because it's a commercial product that works out of the box, but they still have the freedom to configure it as they like".

The latter is achieved using Flow automations. "You have all these cards that you can drag and drop; when the last person left the home, and it's during the day, then turn off all the lights, for example. So it's very easy. And it's drag-and-droppable. You can draw lines between these cards. So it's basically programming, but it doesn't feel like programming."

Emile says that monitoring energy usage is becoming more and more important. "We're very

actively working on new energy solutions that give customers insights and help them actively save energy, and not only save, but also balance their energy usage, because that's really what's hot right now in the market." To that end, the Homey Pro system enables you to monitor energy usage in your home by different devices. "You can see their energy usage. You can also see beautiful charts of all your devices [and] sensors."

Another appealing aspect for many customers is that Homey Pro is very 'privacy first'. "We don't sell data. We're a simple company. We make a great product that we ask some money for, and then you're done. So it's very straightforward. So especially if you compare [it] to big tech, that's a big reason why people choose Homey over Google Home, for example - not only because it's more advanced, but also because they want their home to feel safe." 

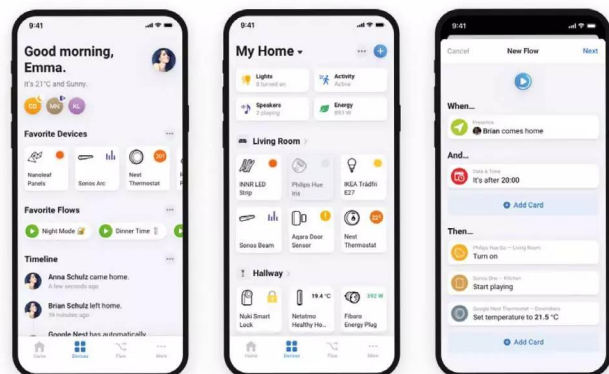

Raspberry Pi Custom DSI Display CM4 Carryboard, and Industrial Tablet

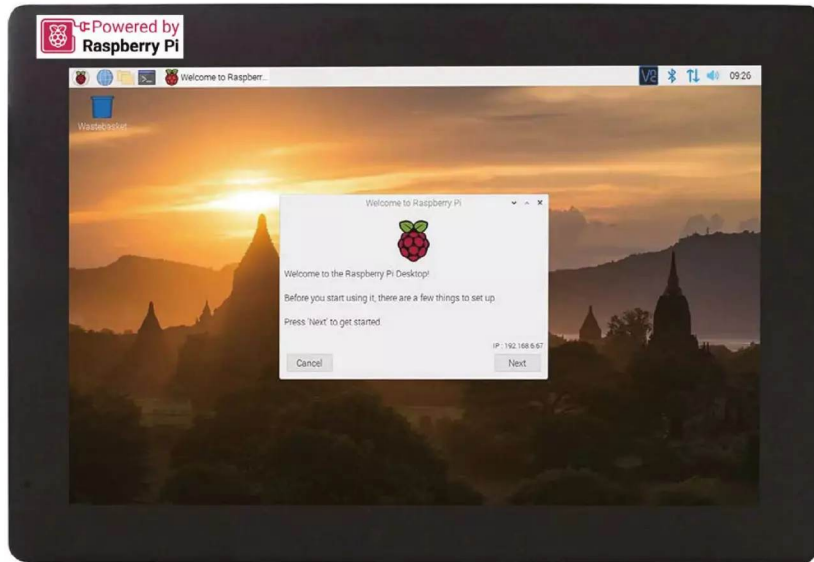

Custom DSI Displays

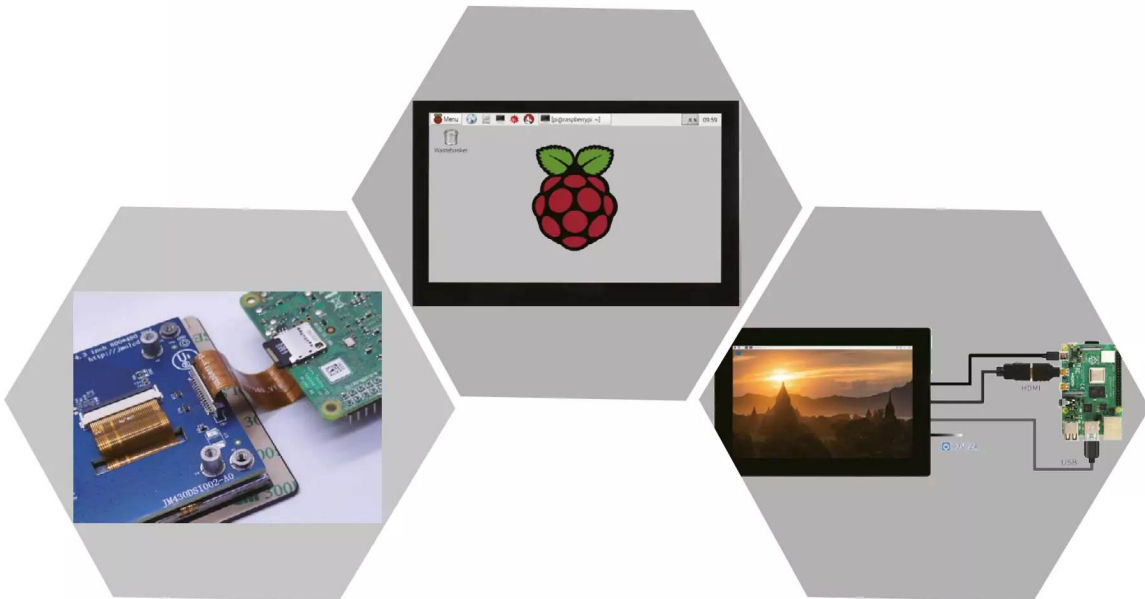

Development of
CM4-compatible carryboard

Industrial Tablet
development capabilities

***Looking for cooperation
partners around the
world.***

Contact us

Tel: +44 7587611960

E-mail: straight@jmolcd.com

Website: www.jmolcd.com



SUBSCRIBE TODAY FOR JUST £10

Get 3 issues + FREE Pico W



Subscriber benefits

- ▶ **FREE Delivery**
Get it fast and for FREE
- ▶ **Exclusive Offers**
Great gifts, offers, and discounts
- ▶ **Great Savings**
Save up to 23% compared to stores

Subscribe for £10

- ▶ Free Pico W
- ▶ 3 issues of The MagPi
- ▶ £10 (UK only)

Subscribe for 6 Months

- ▶ Free Pico W
- ▶ 6 issues of The MagPi
- ▶ £30 (UK) \$43 (USA)
- ▶ €43 (EU) £45 (Rest of World)

📞 Subscribe by phone: **01293 312193**

📧 Subscribe online: **magpi.cc/subscribe**

✉ Email: **magpi@subscriptionhelpline.co.uk**

Subscribe for £10 is a UK-only offer. The subscription will renew at £15 every three months unless cancelled. A free Pico W is included with a six-month subscription in USA, Europe and Rest of World.

SUBSCRIBE TODAY AND GET A

FREE Raspberry Pi Pico W

Subscribe in print today and get a **FREE** development board

- ▶ A brand new RP2040-based Raspberry Pi Pico W development board
- ▶ Learn to code with electronics and build your own projects
- ▶ Make your own home automation projects, handheld consoles, tiny robots, and much, much more

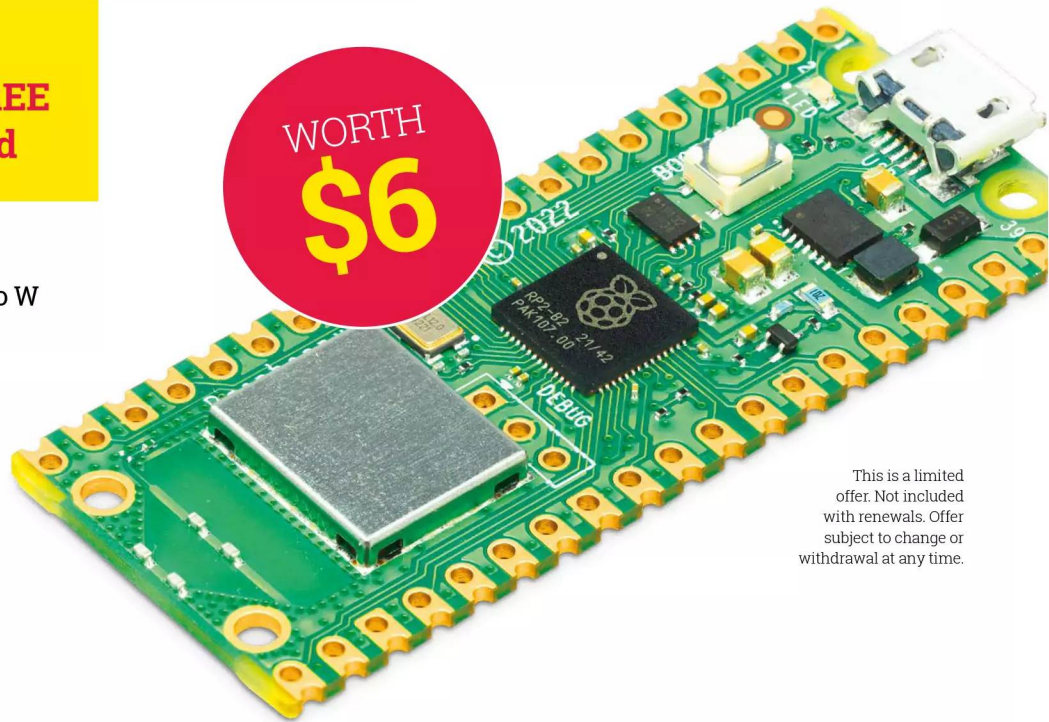

This is a limited offer. Not included with renewals. Offer subject to change or withdrawal at any time.



Buy now: magpi.cc/subscribe



SUBSCRIBE
on app stores

From **£2.29**



ROBOT EXPLORERS!

WITH A RUGGED ROBOT, EQUIPPED WITH WHEELS OR LEGS, YOU CAN EXPLORE THE SURFACE OF A PLANET AND USE SENSORS TO ANALYSE ITS ENVIRONMENT

BY PHIL KING

Whether on another planet, or our own, robot rovers are commonly used to explore hostile environments too dangerous for humans. Equipped with a camera and various sensors robots can analyse the environment and detect dangers. Some even have a robotic arm to manipulate objects.

You can build one of these robots from the many Raspberry Pi robot kits available! These are smaller, and more affordable, making it easy to get involved with robotics from a safe standpoint. Here, we take a look at some of the best, from starter kits to more feature-rich builds such as the 4tronix M.A.R.S. Rover that can handle outdoor terrain. Let's start exploring...

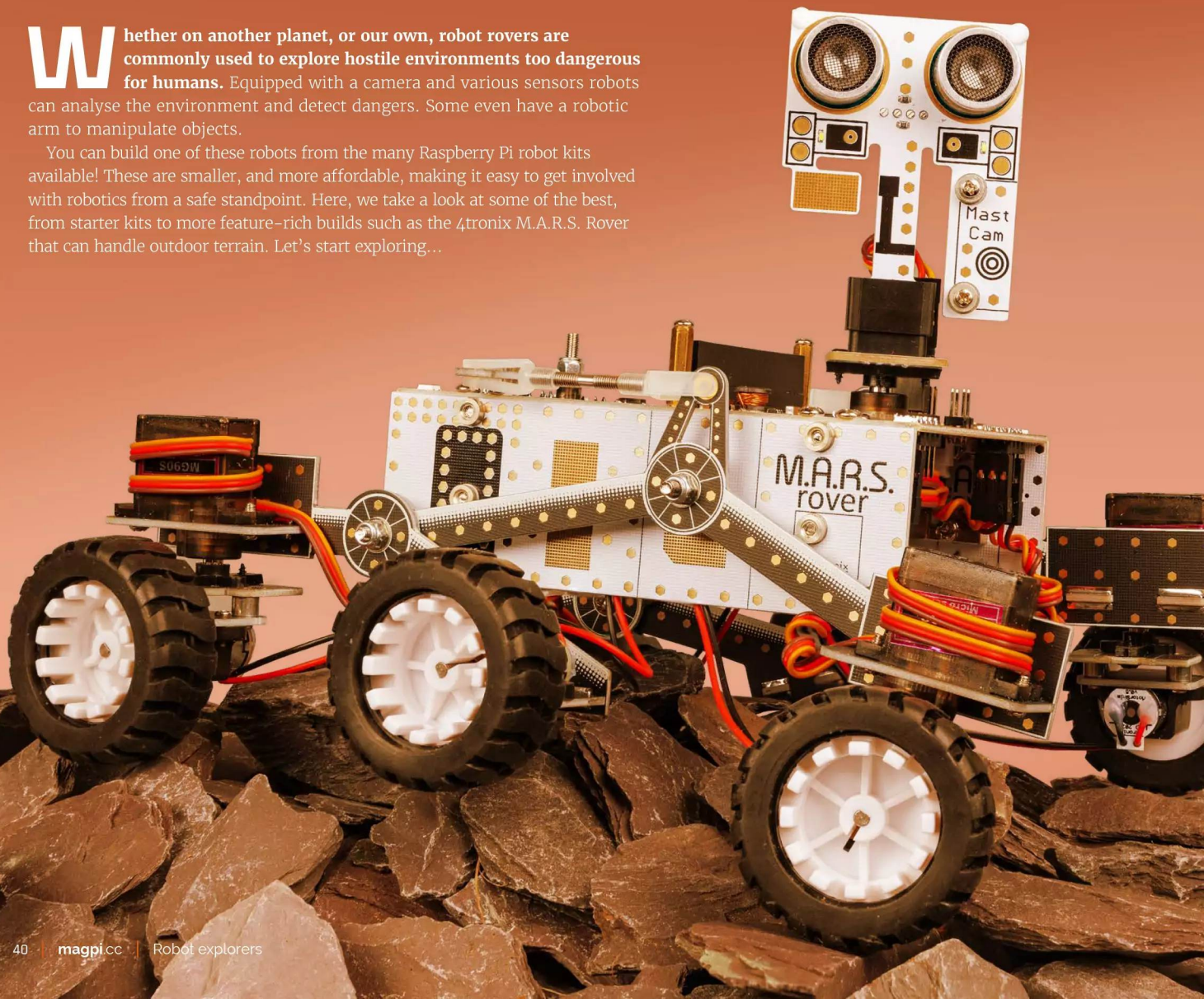

STARTER ROBOTS

IF YOU'RE NEW TO ROBOTICS AND WANT A SIMPLER PROJECT TO GET STARTED WITH, WHY NOT BUILD ONE OF THESE KITS?

	CAMJAM EDUKIT #3	magpi.cc/camjamedu3	£20
<p>One of the most affordable starter kits around, it includes the components needed to build your first wheeled robot, including a motor controller board, two DC motors and wheels, ball castor, mini breadboard, jumper cables and resistors. You even get a couple of sensors: ultrasonic for obstacle detection, and a line follower to track black lines marked on the floor.</p> <p>The only thing missing – apart from a Raspberry Pi and four AA batteries to power it – is a chassis. You can either buy one or use the kit's cardboard box.</p> <p>Detailed online worksheets, based around Python 3 and GPIO Zero, take you through building and programming the robot, including getting it to move autonomously.</p> <p>◀ This entry-level kit is ideal for beginners and even includes a couple of sensors</p>			
	PI2GO MK2	magpi.cc/pi2go2	FROM £43
<p>In the standard Pi2Go kit, you get everything apart from a Raspberry Pi and six AA batteries – if using a Raspberry Pi 4 or 5, you'll need to switch in a 2 × 18650 battery board. There's also a 4WD pack option to convert it into a four-wheeled robot.</p> <p>The main motor driver board is packed with sensors: four analogue light sensors, two infrared, and two line-followers. Two breakout slots let you connect the supplied ultrasonic distance sensor and it includes a four-digit display, although you could switch these out for other Breakout Garden-standard sensors. An extra 12-pin connector enables you to add up to four servos too.</p> <p>◀ This two (or four) wheeled robot is packed with features and sensors, plus expansion options</p>			
	TRILOBOT	magpi.cc/trilobot	FROM £53
<p>Described by Pimoroni as a 'mid-level' robot, the Trilobot is designed to be simple for newcomers to get started with while offering plenty of possibilities for adding extra functionality via numerous ports and headers.</p> <p>The standard Base Kit includes everything you need apart from a Raspberry Pi 4, USB-C power bank, and optional Camera Module. The main PCB seamlessly integrates a DRV8833PWP dual H-bridge motor controller, connected via short cables to the pre-soldered shims of the metal-gear motors. Two moon buggy wheels are supplied alongside a metal ball castor for the rear.</p> <p>While not yet compatible with Raspberry Pi 5 (or Raspberry Pi OS based on Bookworm), the Trilobot is a terrific two-wheeled robot that even features six RGB LEDs for cool underlighting effects.</p> <p>◀ The supplied ultrasonic distance sensor and optional Camera Module are mounted at the front of the robot</p>			

EXPLORER ROBOTS

START EXPLORING THE OUTDOOR TERRAIN OF THE PLANET WITH ONE OF THESE ROBOT KITS, MANY EQUIPPED WITH MULTIPLE SENSORS

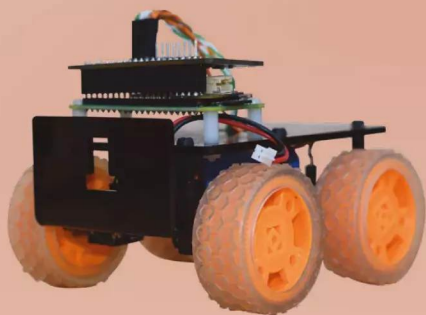

TINY 4WD

magpi.cc/tiny4wd

£55

The Tiny 4WD’s design originated in a tutorial written for *The MagPi* many moons ago, but this is a much-improved version. Controlled by a Raspberry Pi Zero W (not supplied), this mini robot is sturdy and powerful enough to be used outside, even on gravel paths.

The kit contains all you need to build the chassis, including a mount for a Camera Module, while a Pimoroni Explorer pHat drives four motors that spin the large grippy wheels. A mini breadboard is also included, enabling you to add optional sensors.

◀ One of the smallest robots around, the Tiny 4WD is a mini marvel that can handle the outdoors



PICAR-X

magpi.cc/picarx

\$82 (£64)

One of SunFounder’s range of PiCar kits, it has four chunky wheels and is crammed with features including ultrasonic distance and line-follower sensors, a built-in speaker, rechargeable custom battery pack, plus a camera with a servo to rotate it. By streaming live video, you can get a first-person view from the robot. The PiCar-X is programmable in Python or Blockly – online guides and videos help you get started. AI computer vision enables the robot to drive itself and recognise objects, faces, and hand gestures.

◀ Packed with features, this is one smart car – with text-to-speech, it can even talk





ZUMO 2040

magpi.cc/zumo2040

£150

A classic method for navigating tough terrain is to equip a vehicle with caterpillar tracks. That’s the case with the Zumo 2040 from popular robotics brand Pololu. As the name suggests, it’s powered by an RP2040 chip, as featured in Raspberry Pi Pico. So it’s easy to program using MicroPython, C/C++, or the Arduino language. At just 10cm long it’s small, but is jam-packed with features including four proximity sensors (on the front and sides), five downward-facing reflectance sensors for line following or edge detection, and even a built-in IMU (inertial measurement unit).

◀ This mini tracked robot can navigate difficult terrain while using an impressive array of sensors

	<p>TURBOPI</p>	<p>magpi.cc/turbopi</p>	<p>\$190 (£149)</p>
<p>When it comes to manoeuvrability, Mecanum wheels are the ultimate upgrade, enabling a vehicle to move sideways and spin around on the spot. That's why they're used on some forklift trucks. As well as offering 360° omnidirectional movement, HiWonder's TurboPi car carries an HD camera on a pan-tilt mount. This can be used with the OpenCV Python computer vision library to recognise objects and react to hand gestures. There's also a four-channel line follower sensor and a smartphone app for remote control.</p> <p>◀ Mecanum wheels make this one of the most manoeuvrable Raspberry Pi robotic rovers</p>			
	<p>TONYPI</p>	<p>magpi.cc/hwtonypi</p>	<p>\$570 (£447)</p>
<p>Not every robot moves about on wheels – some have legs, like this amazing mechanical humanoid from HiWonder. Powered by Raspberry Pi 4, the TonyPi has a built-in IMU (inertial measurement unit) to help maintain its balance as it walks around – it can even get up from lying on its back. It also boasts a pair of robotic arms with gripping hands to pick up objects. Equipped with an HD camera, its head can tilt and pan to see around. With computer vision, you can get it to recognise and track objects, enabling it to kick a football.</p> <p>◀ This impressive humanoid robot has AI vision, gripping hands, and the ability to walk</p>			
	<p>RASPCLAWS HEXAPOD</p>	<p>magpi.cc/raspclaws</p>	<p>£98</p>
<p>There are quite a few kits available for building an insect-like Raspberry Pi robot. While some have four legs, this one from Adeep has six limbs as well as a self-stabilisation mode, making it capable of creepy-crawling over rough ground. With a camera mounted on a servo on top and four NeoPixel strips for lighting, it can also look around and use computer vision to recognise objects and detect motion. Note that for lower power drain and legacy software compatibility, it's advisable to use it with a Raspberry Pi 3B/3B+.</p> <p>◀ This bug-like robot can crawl over surfaces and use a camera to look around</p>			

UNDERWATER ROV

Exploring the land with a robotic rover is cool, but getting a submersible ROV (remotely operated vehicle) to dive under the water is even cooler. We've seen a few such Raspberry Pi-based projects over the years, one of the most impressive being the underwater drone built by Ievgenii Tkachenko (see magpi.cc/80). Its four motors, lights, and gyroscope are handled by Raspberry Pi, which also sends a live video stream. An onshore Wi-Fi router is connected to the submersible via an Ethernet cable, enabling remote control from a smartphone. Similar commercial ROVs are used for boat inspections and to aid rescue operations.



M.A.R.S. ROVER ROBOT

ONE OF THE BEST ROBOT KITS AROUND, IT LETS YOU EXPLORE TERRAIN JUST LIKE A NASA MARS ROVER, AND EVEN USES A SIMILAR SUSPENSION SYSTEM

Mounted on a mast that can be rotated, an ultrasonic distance sensor aids navigation

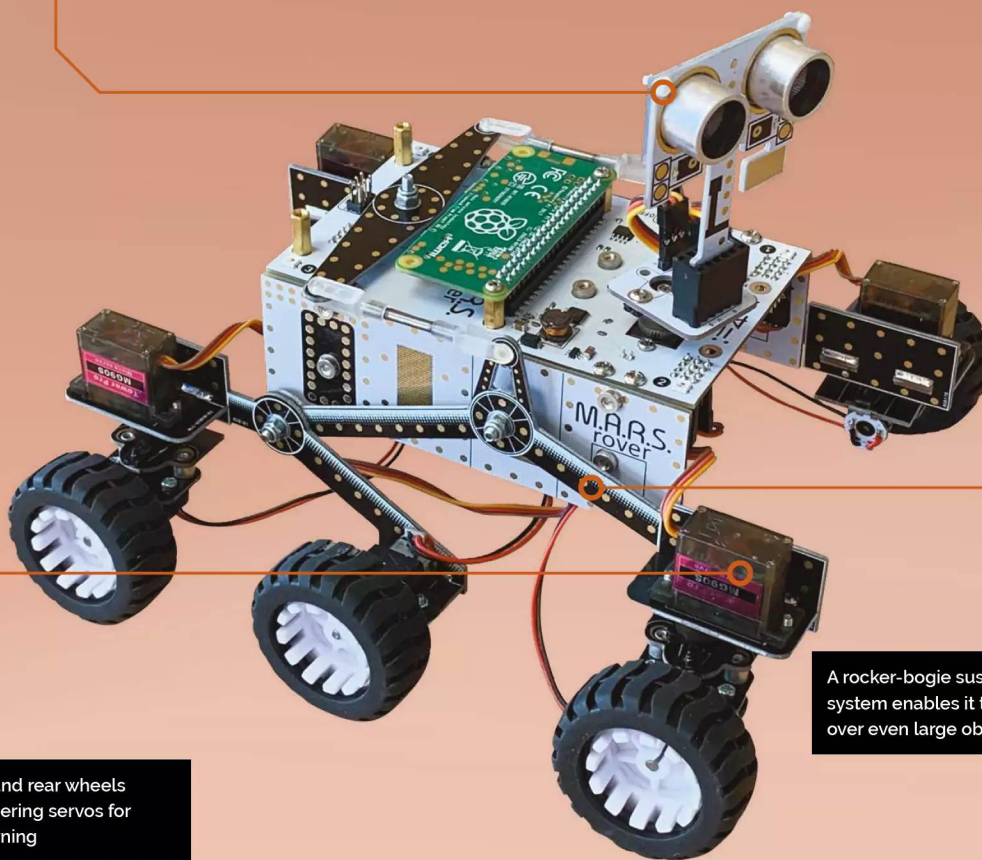

The front and rear wheels feature steering servos for quicker turning

A rocker-bogie suspension system enables it to roll over even large obstacles

M.A.R.S. ROVER ROBOT FOR PI ZERO

magpi.cc/marsrover

£126



◀ The 4tronix M.A.R.S. Rover looks very much like the real thing and can handle tough terrain

IT'S AMAZING TO WATCH IN ACTION AND FAR SUPERIOR TO FIXED-WHEEL BUGGIES

▼ A clever rocker-bogie suspension system enables M.A.R.S. Rover to clamber over large obstacles

Not only does this robot look remarkably similar to the real Mars Curiosity rover, it uses the same type of rocker-bogie suspension system developed by NASA. This allows the six wheels to move up and down semi-independently so they all maintain contact with the ground while the rover's body stays level. It's amazing to watch in action and far superior to fixed-wheel buggies in handling difficult terrain. It can even clamber over fairly large rocks.

The kit does take a little while to assemble, but the result is a quality build with metal PCB panels, six N20 micro gear motors, and chunky wheels. The finishing touch is a mast with an ultrasonic distance sensor to the top – it's mounted on a servo so you can rotate it. The four corner wheels have steering servos too, enabling quicker turning. An optional keypad can be added on the rear for hands-on route programming.

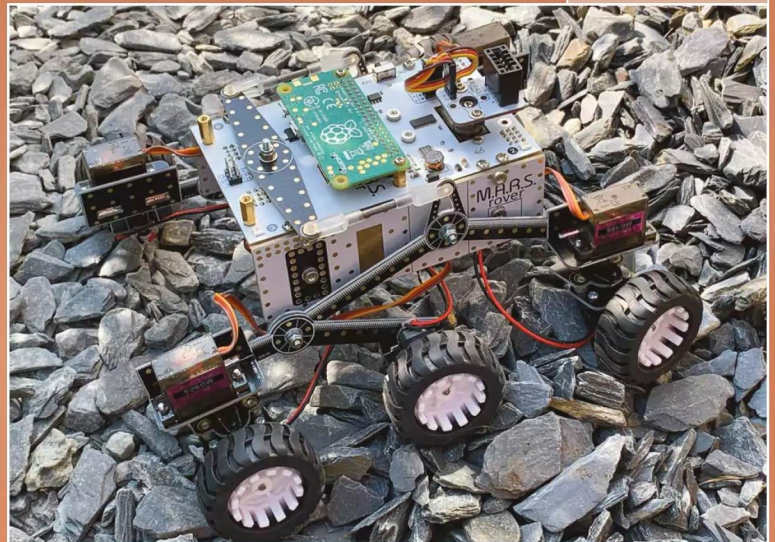

REAL MARS ROVER: CURIOSITY

The 4tronix M.A.R.S. Rover was inspired by NASA's Curiosity rover, which – after a journey of 350 million miles – landed on the Red Planet in 2012 and is still operational today (along with close relative Perseverance, which arrived in 2021). An ingenious suspension system for its six wheels helps it to navigate the rocky landscape. Equipped with an array of scientific instruments, along with a robotic arm and two cameras, its main mission is to examine the Martian geology (it can drill into rocks to obtain samples to analyse) and look for any signs that life could once have existed there.



ROBOT SENSORS

GIVE YOUR ROBOT AN AWARENESS OF ITS SURROUNDINGS BY ADDING ONE OR MORE SENSORS

**NEXT MONTH!
START BUILDING
YOUR ROBOT!**

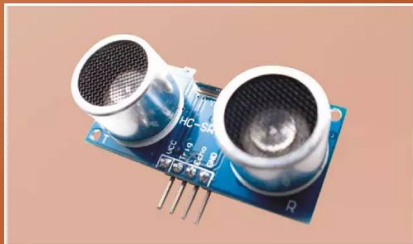

ULTRASONIC

magpi.cc/hrso4

£5

Unless it has the more complicated computer vision, the most common way a robot can detect large obstacles is to use an ultrasonic sensor such as the HC-SR04. This works like a form of sonar, and involves emitting a signal and then listening for the echo to return. The time delay indicates the distance to the object.



TEMPERATURE & MORE

magpi.cc/wsbme280

£9

A key metric for analysing your robot's environment is the ambient temperature. Many popular temperature sensors can also measure relative humidity and barometric pressure. The BME280 measures all three and delivers the data via a digital output to Raspberry Pi, so there's no need to use an ADC to decode analogue readings.



GAS

magpi.cc/gassensor

£6

When exploring an unknown environment with your rover, you'll want to sniff out any dangerous gases. The MQ-5 gas sensor can detect LPG, natural gas, and coal gas. It has both digital and analogue output pins. You could combine it with a flame sensor (e.g. magpi.cc/flamesensor) to detect both gas leaks and fires.



SOUND

magpi.cc/soundsensor

£4

Your robot may have eyes (or at least ultrasonic object detection) to help it find its way around, but adding 'ears' can aid it in understanding its surroundings. This sound sensor has an adjustable loudness threshold – when reached, it switches the digital output to high. Alternatively, you could use a USB mic to record and analyse sounds.



MOTION

magpi.cc/imu9dof

£15

An IMU can determine a robot's motion and orientation. Sensors come with varying DOF (degrees of freedom); a 9DOF one (as here) can detect three-axis acceleration, three-axis gyroscopic motion, and three-axis compass heading. While not essential for a wheeled rover, an IMU is vital for a walking robot's sense of balance.



CAMERA

magpi.cc/camera

£24

When controlling your rover remotely, a camera is a vital aid for navigation and getting a detailed view of its environment. Whether you use a Raspberry Pi Camera Module or a USB webcam, there's the option of using computer vision such as OpenCV (magpi.cc/opencv) to recognise objects automatically. 

Your FREE guide to making a smart TV

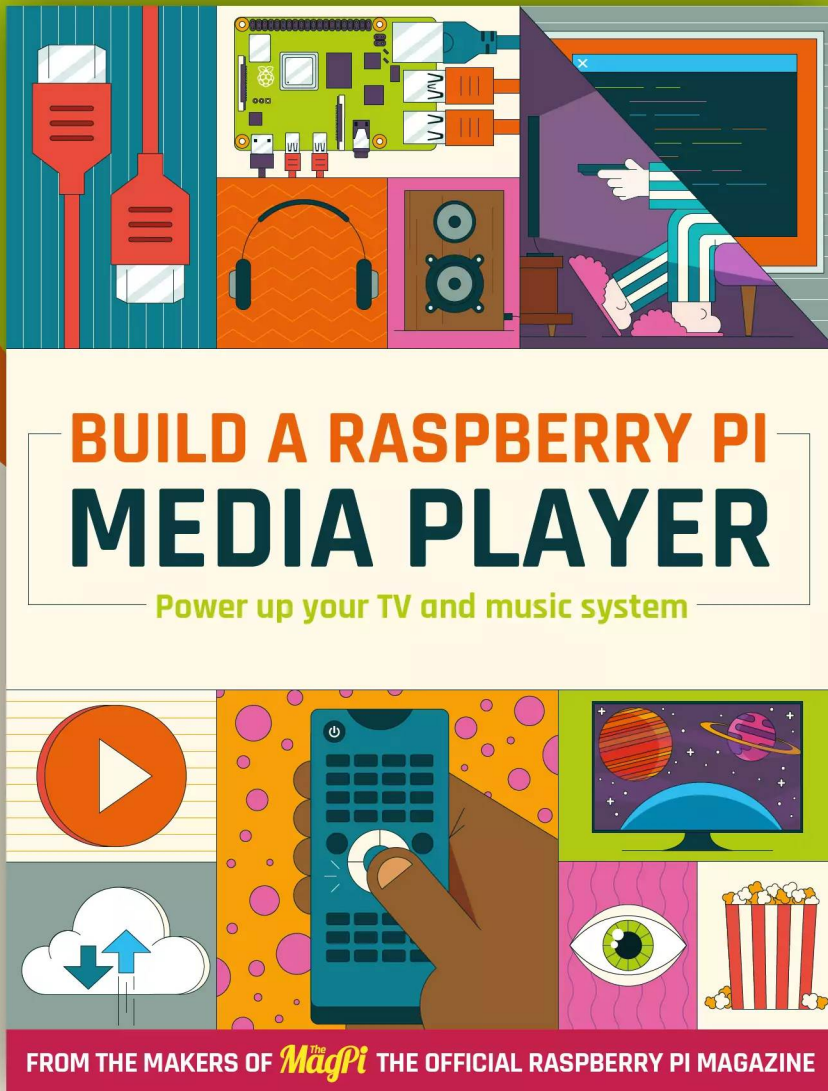

magpi.cc/mediaplayer

Using M.2 HAT+ with Raspberry Pi 5

Raspberry Pi M.2 HAT+ M Key enables you to connect M.2 peripherals such as NVMe drives and other PCIe accessories to Raspberry Pi 5's PCIe interface



Nate Contino

Nate is a retrofuturist and writes documentation for Raspberry Pi.

lambdalattitudinarians.org

The M.2 HAT+ adapter board converts between the PCIe connector on Raspberry Pi 5 and a single M.2 M key edge

connector. You can connect any device that uses the 2230 or 2242 form factors. The M.2 HAT+ can supply up to 3A of power.

The M.2 HAT+ uses Raspberry Pi's HAT+ specification, which allows Raspberry Pi OS to automatically detect the HAT+ and any connected devices.

The included threaded spacers provide ample room to fit the Raspberry Pi Active Cooler beneath an M.2 HAT+.

The M.2 HAT+ is only compatible with the Raspberry Pi Case for Raspberry Pi 5 if you remove the lid and the included fan.

“ Ensure your Raspberry Pi runs the latest software ”

Features

- Single-lane PCIe 2.0 interface (500 MB/s peak transfer rate)
- Supports devices that use the M.2 M key edge connector
- Supports devices with the 2230 or 2242 form factors
- Supplies up to 3A to connected M.2 devices

- Power and activity LEDs
- Conforms to the Raspberry Pi HAT+ specification (magpi.cc/hatplusspec)

Includes:

- ribbon cable
- 16mm GPIO stacking header
- 4 threaded spacers
- 8 screws
- 1 knurled double-flanged drive attachment screw to secure and support the M.2 peripheral

Installation

To use the Raspberry Pi M.2 HAT+, you will need a Raspberry Pi 5

Each M.2 HAT+ comes with a ribbon cable, GPIO stacking header, and mounting hardware. Complete the following instructions to install your M.2 HAT+:

First, ensure your Raspberry Pi runs the latest software. Run the following command to update:

```
sudo apt update && sudo apt upgrade
```

Next, ensure that your Raspberry Pi firmware is up to date. Run the following command to see what firmware you're running:

```
sudo rpi-eeprom-update
```

If you see December 6, 2023 or a later date, proceed to the next step. If you see a date earlier than December 6, 2023, run the

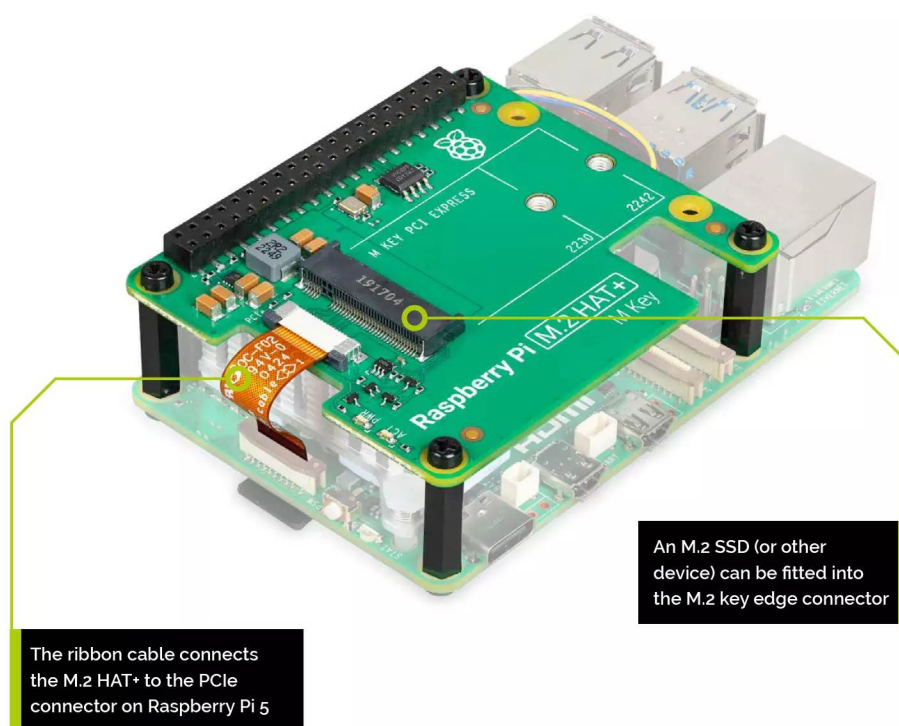

You'll Need

- ▶ Raspberry Pi 5
magpi.cc/raspberrypi5
- ▶ M2 HAT+
magpi.cc/m2hatplus
- ▶ NVMe Drive (optional)



Warning! Power

Always disconnect your Raspberry Pi from power before connecting or disconnecting a device from the M.2 slot to avoid damaging it.

following command to open the Raspberry Pi Configuration CLI:

```
sudo raspi-config
```

Under Advanced Options > Bootloader Version, choose Latest. Then, exit `raspi-config` with Finish or the **ESC** key.

Run the following command to update your firmware to the latest version:

```
sudo rpi-eeprom-update -a
```

Then, reboot with `sudo reboot`.

1. Disconnect the Raspberry Pi from power before beginning installation.
2. The M.2 HAT+ is compatible with the Raspberry Pi 5 Active Cooler. If you have an Active Cooler, install it before installing the M.2 HAT+.
3. Install the spacers using four of the provided

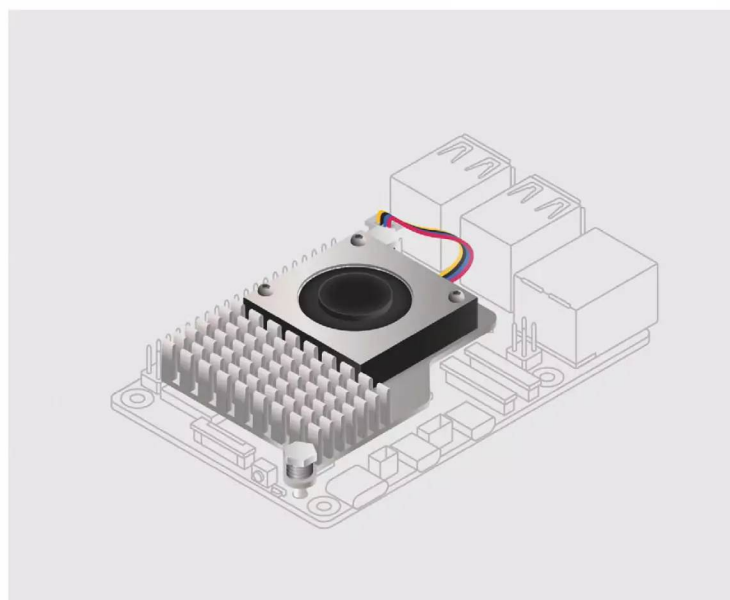

Top Tip

AI Kit

The M.2 HAT+ also enables you to use other devices such as the Hailo AI module found in the Raspberry Pi AI Kit. magpi.cc/aikit

screws. Firmly press the GPIO stacking header on top of the Raspberry Pi GPIO pins; orientation does not matter as long as all pins fit into place. Disconnect the ribbon cable from the M.2 HAT+, and insert the other end into the PCIe port of your Raspberry Pi. Lift the ribbon cable holder from both sides, then insert the cable with the copper contact points facing inward, towards the USB ports. With the ribbon cable fully and evenly inserted into the PCIe port, push the cable holder down from both sides to secure the ribbon cable firmly in place.

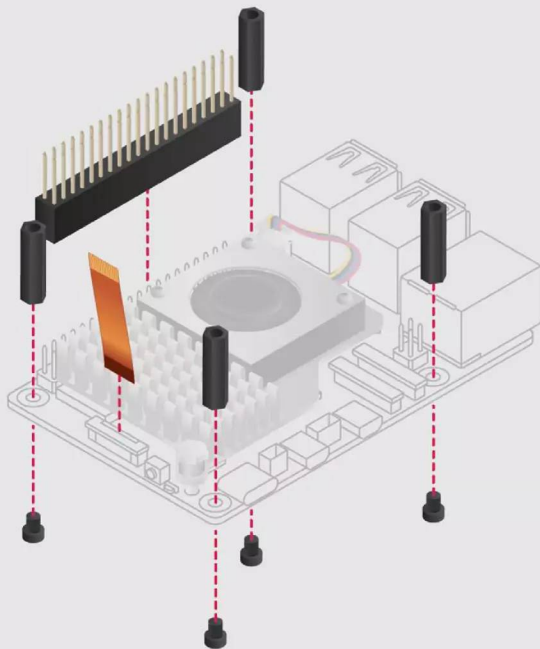

4. Set the M.2 HAT+ on top of the spacers, and use the four remaining screws to secure it in place.

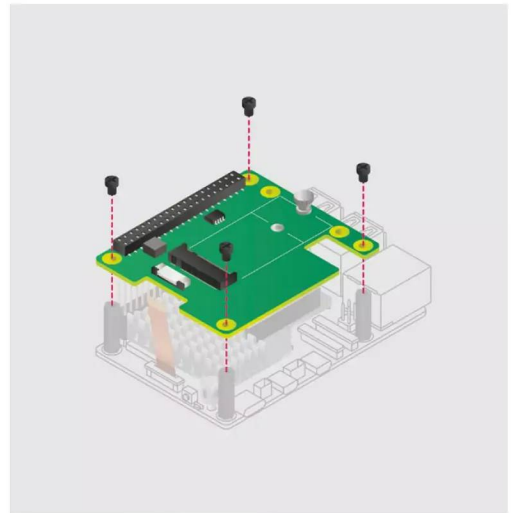

5. Insert the ribbon cable into the slot on the M.2 HAT+. Lift the ribbon cable holder from both sides, then insert the cable with the copper contact points facing up. With the ribbon cable fully and evenly inserted into the port, push the cable holder down from both sides to secure the ribbon cable firmly in place.

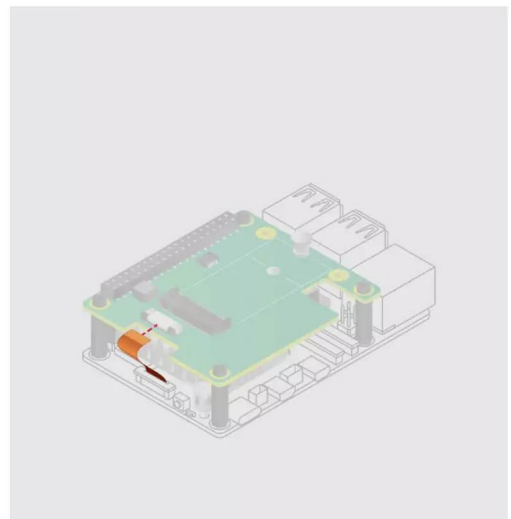

- Remove the drive attachment screw by turning the screw counter-clockwise. Insert your M.2 SSD into the M.2 key edge connector, sliding the drive into the slot at a slight upward angle. Do not force the drive into the slot: it should slide in gently.

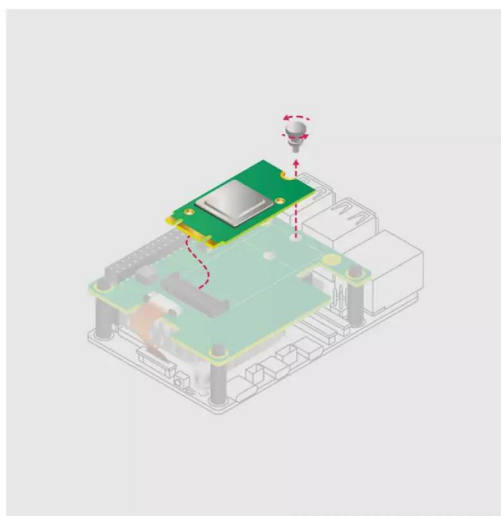

- Push the notch on the drive attachment screw into the slot at the end of your M.2 drive. Push the drive flat against the M.2 HAT+, and insert the SSD attachment screw by turning the screw clockwise until the SSD feels secure. Do not over-tighten the screw.

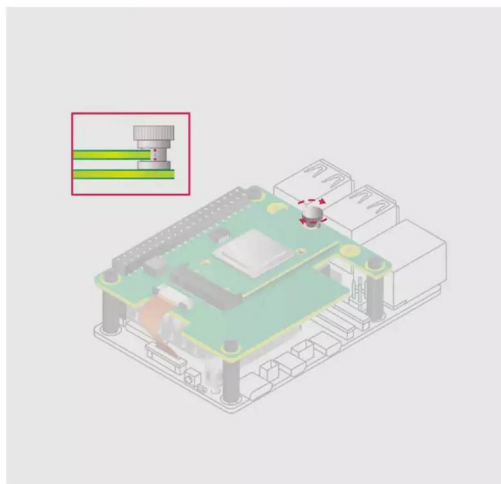

- Congratulations, you have successfully installed the M.2 HAT+. Connect your Raspberry Pi to power; Raspberry Pi OS will automatically detect the M.2 HAT+. If you use Raspberry Pi Desktop, you should see an icon representing the drive on your desktop. If you don't use a desktop, you can find the drive at `/dev/nvme0n1`. To make your drive available for file access automatically, consider configuring automatic mounting (magpi.cc/automount).

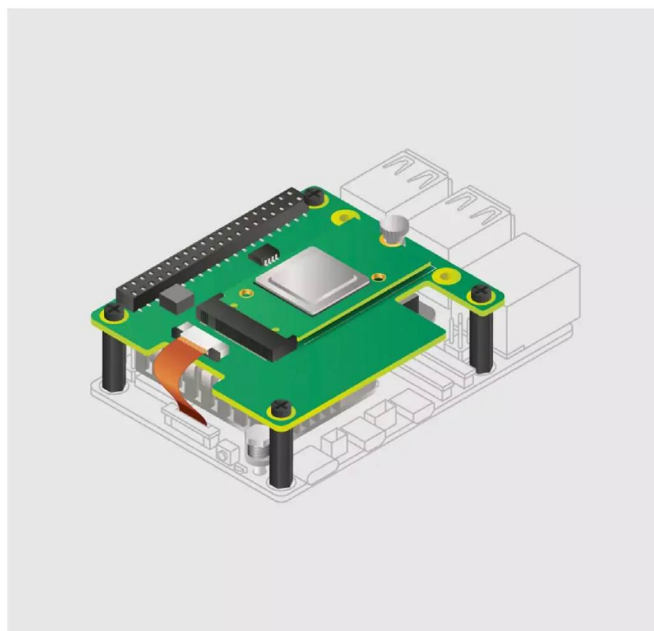

Boot from NVMe

To boot from an NVMe drive attached to the M.2 HAT+, complete the following steps:

- Format your NVMe drive using Raspberry Pi Imager (magpi.cc/installimager). You can do this from your Raspberry Pi if you already have an SD card with a Raspberry Pi OS image.
- Boot your Raspberry Pi into Raspberry Pi OS using an SD card or USB drive to alter the boot order in the persistent on-board EEPROM configuration.
- In a terminal on your Raspberry Pi, run `sudo raspi-config` to open the Raspberry Pi Configuration CLI.
- Under Advanced Options > Boot Order, choose NVMe/USB boot. Then, exit `raspi-config` with Finish or the Escape key.
- Reboot your Raspberry Pi with `sudo reboot`.

For more information, see NVMe boot (magpi.cc/nvmeboot).

Time travel experiments in Python

Create inventive new clocks and calendars using Python's built-in datetime module



Sean McManus

Author of Scratch Programming in Easy Steps, Mission Python, and Web Design in Easy Steps. Get free chapters at Sean's website.

sean.co.uk

MAKER

We can't change the direction we hurtle through time, but we can change how we look at the journey, and maybe, even, how we feel about it. We'll show you how to use Python's `datetime` module to create new clock and calendar designs that help to improve your productivity. Using a countdown clock, you can easily see how much time is left in the working day, so you can schedule work to fit. A bar graph calendar shows where you are in the day, month and year, to help you measure your progress toward your goals.

01 Santa Claus is coming!

Listing 1 is the 'Hello World!' of countdown clocks, showing how long it is until Christmas. It uses the `datetime` module to make an object called `today` that contains the current date and time. It then creates a similar object for Christmas Day. As the program shows, you can subtract one `datetime` object from another to get the difference between them. The result is accurate to a fraction of a second, but you'll see later how to extract just the number of days. You could use this code to count down to a deadline, birthday or holiday.

02 Understanding Pygame's layout

To draw the calendar (see Listing 2), we'll use Pygame, which is installed in Raspberry Pi OS desktop. Run this code from Thonny. In Pygame, you create a surface, which is a canvas to draw on. You can then copy (or 'blit') images, shapes or text onto it. Our window size is 1024 × 768

pixels, to match the resolution of the eight-inch screen, and the surface for the window is called `calendar_surface`.

03 Adding words and bar graphs

The calendar has three coloured rows: the top one shows the date, the middle one the month, and the bottom one the year. Each row is 256 pixels high, a third of the window height. The magic is that each row is also a bar graph, showing progress through the day, month and year. The `draw_bar()` function is passed the fraction to show (e.g. 0.5), the row number between 0 and 2, the background and foreground colours for the bar, and the text to show on it. The colours are in the format `(red,`

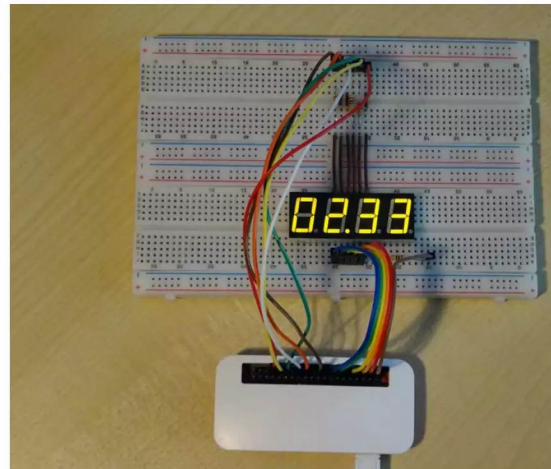

▲ The countdown clock shows me how long until we finish for the day, so we can easily choose the biggest task that will fit

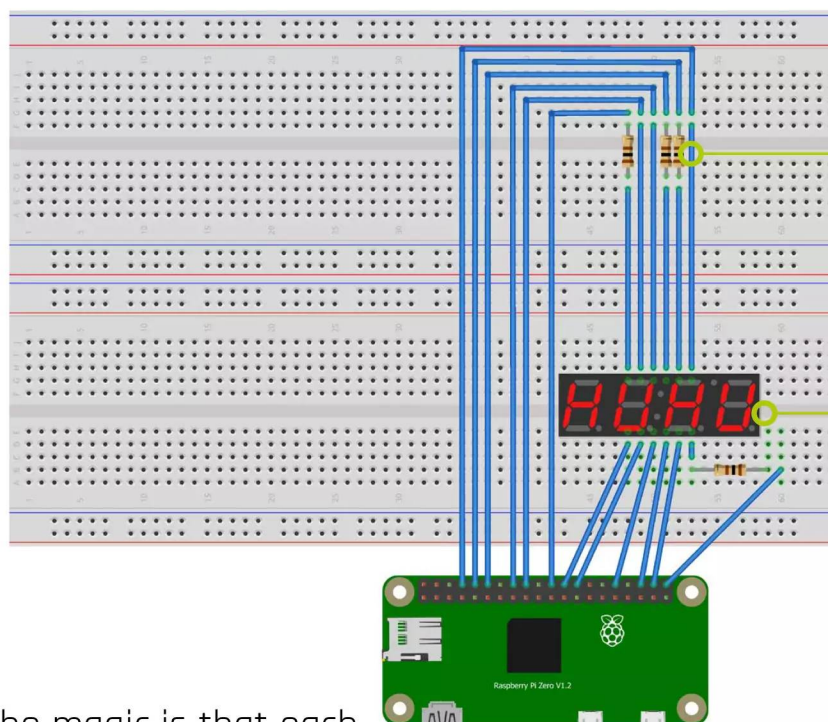

For this type of seven-segment display, place a resistor between the digit pins and Raspberry Pi to protect the LEDs.

You can independently control each segment and decimal point on this display.

“ The magic is that each row is also a bar graph ”

green, blue). The Pygame Rect object stores the coordinates for the bar as (left, top), (width, height) and the `pygame.draw.rect()` function creates a filled rectangle. First a bar is drawn full width (the background colour). Then a bar is drawn with the width of the fraction for that row.

04 Adding the text

The text is written twice (lines 12 to 15), first in silver, and then slightly offset in white, to simulate a shadow. Line 11 sets the font and font size. If you experiment with Pygame, be aware that you won't see anything change until you run `pygame.display.update()` as shown in line 28.

05 Calculating the progress

The `draw_calendar()` function calculates the fractions. The current date and time are stored in the `today` object. We can extract parts using `today.year`, `today.hour` and `today.`

`minute`. The `day_progress` variable calculates the minutes elapsed in the day and then divides it by the total minutes in a day. To convert the day number into a piece of text (or 'string') for display, we use `str(today.day)`. The `month_progress` is calculated by dividing the current day number by the number of days in the month. List indexes start at zero but `datetime` month numbers start at 1, so we subtract 1 from the month number to use it as an index for the `days_in_month` list. Using `today.strftime("%B")` gets us the month name, as a string, from the datetime object. The `year_progress` adds the days in the past months to today's day number and divides the total by the days in the year, accounting for leap years.

06 Going loopy

The final loop (lines 30 to 36) keeps calling `draw_calendar()` to update the screen at one-minute intervals. If you watch closely, you can see the top bar slowly advance. Our prototype

You'll Need

- ▶ 4-digit 7-segment display 5461AS aliexpress.com or ebay.co.uk
- ▶ Breadboard magpi.cc/bboard
- ▶ Dupont wires magpi.cc/dupontwires

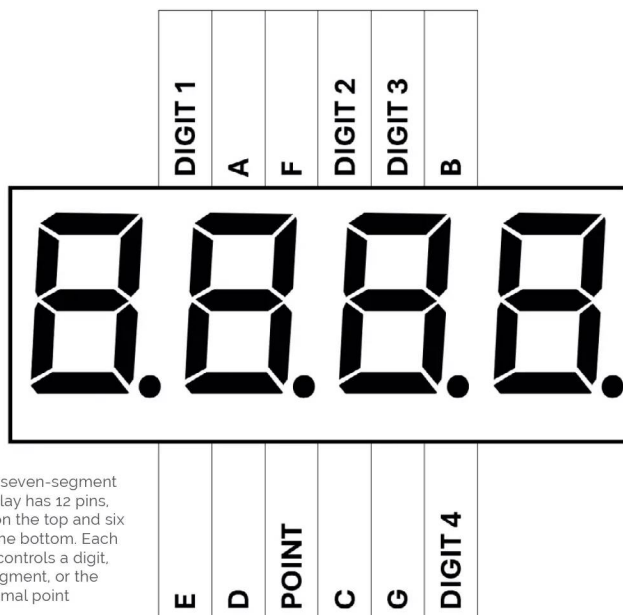

► The seven-segment display has 12 pins, six on the top and six on the bottom. Each pin controls a digit, a segment, or the decimal point

used `time.sleep(60)` to pause for a minute between each update. In the final program, a `for` loop repeats a one-second pause, so it can check whether you want to close the program.

07 Connecting the countdown circuit

The four-digit seven-segment display is perfect for clocks and can also show most letters (k, m, q, v, w and x can't be done). Various types are available. Mine is labelled 5461AS and has 12 pins, which you connect to Raspberry Pi's GPIO array. Four of the pins control which digit lights up. To protect the LEDs, put a 100 ohm resistor between these pins and your Raspberry Pi. Check the documentation for connection instructions if you're using a different display.

08 Designing the number shapes

Take a look at Listing 3, which runs the countdown clock. Each digit on the display has seven segments, which can be either lit or off. The segments are ordered in a clockwise direction, starting at the top and ending with the middle bar. They're usually known by the letters A to G. The `number_segments` list contains the on/off settings for the segments in each number. The first number is zero, so all the segments are lit except the middle bar. The last one is nine, so all the segments are lit except E.

Top Tip

Keep the code simple

The calendar's leap year calculation is only accurate until the year 2100, but this code is highly unlikely to be in use in 76 years' time.

09 Setting up the pins

We're using the `RPi.GPIO` module to control the GPIO pins on Raspberry Pi. It operates in two modes, `BOARD` or `BCM`. In `BOARD`, the pin numbers are the physical positions on the board. In `BCM` mode, you use the channel numbers on the processor. For simplicity and better compatibility, we're using `BOARD`. We set all the pins we're using to be outputs. The `segment_selectors` list contains the pin numbers that control segments A to G on the display. The `digit_selectors` list contains the pins that control the digits from left to right.

10 Displaying a number

The display tricks your eye. Only one digit is lit at a time but they change so fast that you see them all together. The `show_number()` function displays a number in a digit position (from 0 to 3). To choose the digit you want to light, you set its connected pin to 0. To set a segment in that digit, you set its connected pin to 1. The `GPIO.output()` function enables you to pass a list of values to a list of pins. In line 23, it's used to activate the right digit. In line 24, `GPIO.output()` sends the appropriate `number_segments` values to the pins for the segments. The decimal point is turned on for the second digit to separate hours from minutes.

listing1.py

DOWNLOAD THE FULL CODE:

magpi.cc/seancode

► Language: Python

```
001. import datetime
002. today = datetime.datetime.now()
003. xmas = datetime.datetime(
004.     year=today.year, month=12, day=25)
004. days_to_xmas = xmas -
    datetime.datetime.now()
005. print(days_to_xmas)
```



11 Calculating the time left

Datetime's `timedelta` class is ideal for calculating simple time differences. In lines 31 to 32, we create `timedeltas` for the end time (17:30) and the current time. Line 33 works out the difference between them and formats the result as a string. We've added a 0 at the start so there are two digits for single-digit hours. If the time difference is negative, the string is set to zeroes. You could set different end times depending on the day of the week, or have multiple countdowns to lunchtime and home time.

◀ The dark bars on the progress calendar show we've passed half-way in May and have completed more than a third of the year already

listing2.py

► Language: **Python**

DOWNLOAD THE FULL CODE:



magpi.cc/seancode

```

001. import pygame, datetime, time
002. from pygame.locals import *
003. pygame.init()
004. calendar_surface = pygame.display.set_
005. mode((1024, 768))

006. def draw_bar(fraction, row, color, color2,
007. text):
008.     box = Rect((0, row * 256), (1024, 256))
009.     pygame.draw.rect(calendar_surface, color,
010. box)
011.     box = Rect((0, row * 256), (fraction * 1024,
012. 256))
013.     pygame.draw.rect(calendar_surface, color2,
014. box)
015.     font_object =
016.     pygame.font.Font('freesansbold.ttf', 160)
017.     text_surface = font_object.render(
018. text, True, (255, 255, 255))
019.     shadow_surface = font_object.render(
020. text, True, (190, 190, 190))
021.     calendar_surface.blit(shadow_surface, (
022. 56, 61 + (row * 256)))
023.     calendar_surface.blit(text_surface, (
024. 50, 55 + (row * 256)))
025.
026. def draw_calendar():
027.
028.     days_in_month = [31, 28, 31, 30, 31, 30, 31,
029. 31, 30, 31, 30, 31]
030.     today = datetime.datetime.now()
031.     if today.year % 4 == 0:
032.         days_in_month[1] = 29 # leap year
033.     day_progress = (((today.hour * 60) +
034. today.minute) / (60*24))
035.     draw_bar(day_progress, 0, (204,153,255),
036. (178,102,255), str(today.day))
037.     month_progress = today.day /
038. days_in_month[today.month - 1]
039.     draw_bar(month_progress, 1, (255,153,255),
040. (255,102,255), today.strftime("%B"))
041.     year_progress = (sum(days_in_month[
042. 0:today.month - 1]) + today.day) / sum(
043. days_in_month) # Split misses last value
044.     draw_bar(year_progress, 2, (255,153,204),
045. (255,102,178), str(today.year))
046.     pygame.display.update()
047.
048. while True:
049.     draw_calendar()
050.     for seconds in range(60):
051.         for event in pygame.event.get():
052.             if event.type == pygame.QUIT:
053.                 pygame.quit()
054.                 time.sleep(1)

```

Top Tip

Everything but the sync

The calendar updates at one-minute intervals, but it's not synchronised with the clock. Depending on when you start it, it might update mid-way through each minute.

► The four-digit display measures 5cm by 1.8cm and costs a few pounds online.

12 Displaying the time remaining

The `for` loop starting at line 37 extracts the number for each digit from the `time_difference` string and calls the `show_number` function to display it. The `time_difference` string always has a 0 on the front, even if the hours are 10 or more. That's why negative indexes are used to find each digit number, counting from the end of the string. The third digit we want to display, for example, is at position `-5`. Strings are great for extracting individual numerals from a long number, but we have to send `show_number()` an integer, because it will be used as a list index to find the segments to light. Line 38 uses `int()` to do the conversion. The tiny time delay in line 39 ensures you see all the digits at once, and the `while` loop keeps updating the time and refreshing the display. 

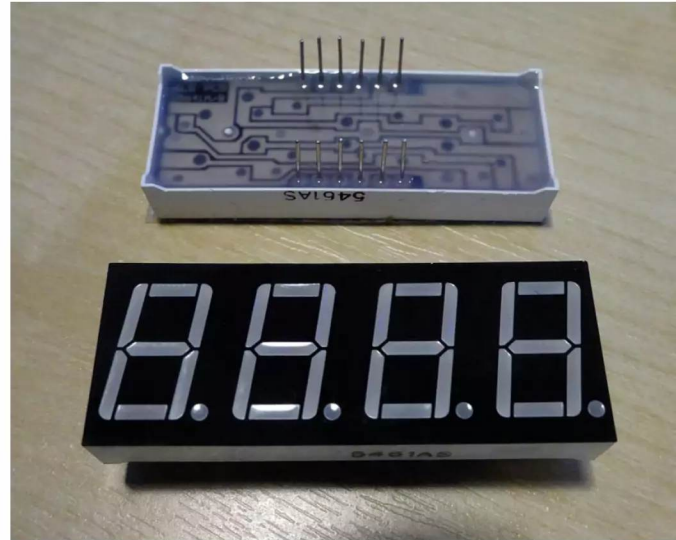

listing3.py

► Language: Python

DOWNLOAD THE FULL CODE:

 magpi.cc/seancode

```

001. import sys, time, datetime
002. from datetime import timedelta
003. import RPi.GPIO as GPIO
004.
005. number_segments = [
006.     [1,1,1,1,1,0], [0,1,1,0,0,0],
007.     [1,1,0,1,1,0,1], [1,1,1,1,0,0,1],
008.     [0,1,1,0,0,1,1], [1,0,1,1,0,1,1],
009.     [1,0,1,1,1,1,1], [1,1,1,0,0,0,0],
010.     [1,1,1,1,1,1,1], [1,1,1,1,0,1,1]
011. ]
012. segment_selectors = [18, 8, 36, 26, 24, 16, 38]
013. digit_selectors = [22, 12, 10, 40]
014. decimal_point = 32
015. GPIO.setmode(GPIO.BOARD)
016. GPIO.setwarnings(False)
017. for pin in segment_selectors + digit_selectors +
    [decimal_point]:
018.     GPIO.setup(pin, GPIO.OUT)
019.
020. def show_number(digit, number):
021.     switches = [1, 1, 1, 1]
022.     switches[digit] = 0
023.     GPIO.output(digit_selectors, switches)
024.     GPIO.output(segment_selectors,
025.                 number_segments[number])
026.     if digit == 1:
027.         GPIO.output(decimal_point, 1) # on
028.     else:
029.         GPIO.output(decimal_point, 0) # off
030. while True:
031.     end_time = timedelta(
032.         hours = 17, minutes = 30)
033.     now_time = timedelta(hours =
034.         datetime.datetime.now().hour, minutes =
035.         datetime.datetime.now().minute)
036.     time_difference = "0" + str(
037.         end_time - now_time)
038.     if "." in str(time_difference):
039.         time_difference="00:00:00"
040.     time_index = [-8,-7,-5,-4]
041.     for digit in [0, 1, 2, 3]:
042.         show_number(digit, int(
043.             time_difference[time_index[digit]]))
044.     time.sleep(0.005)

```

AN INTRODUCTION TO C&GUI PROGRAMMING

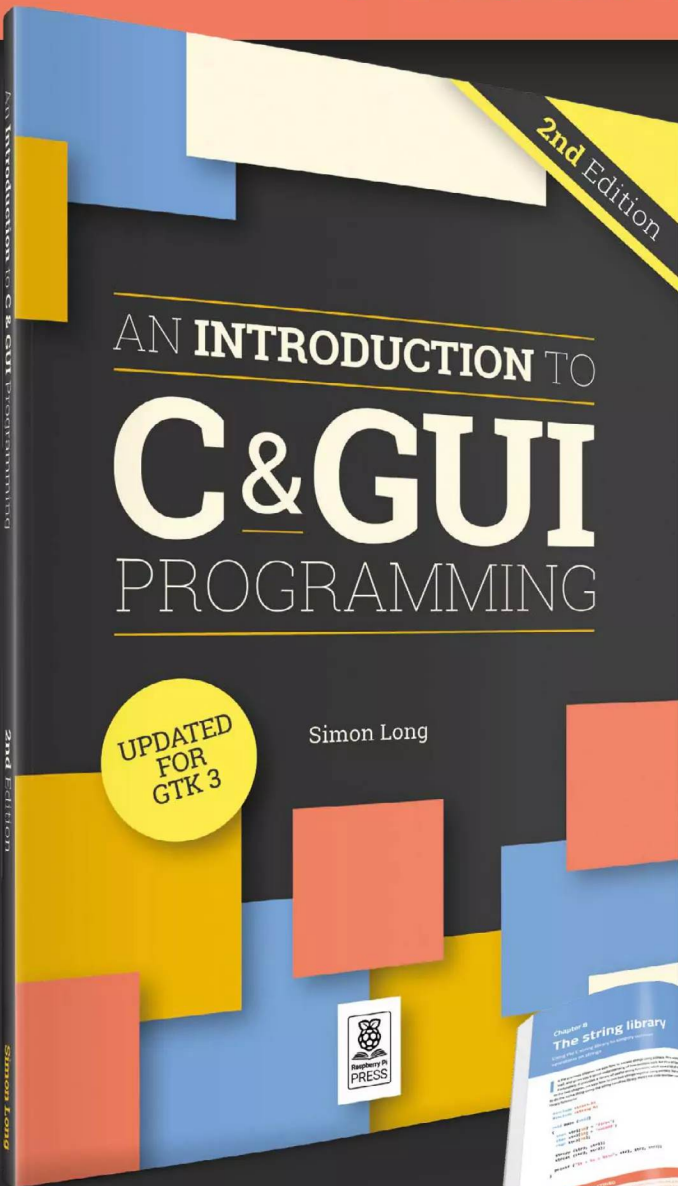

All you need to know
to write simple
programs in C and
start creating GUIs

Inside:

- Create simple command-line C programs
- Control flow with conditions and loops
 - Handle variables, strings, and files
 - Design graphical user interface applications in C
- Handle user input with buttons and menus
 - Use advanced UI features such as data stores and dialogs

£10 with **FREE**
worldwide delivery

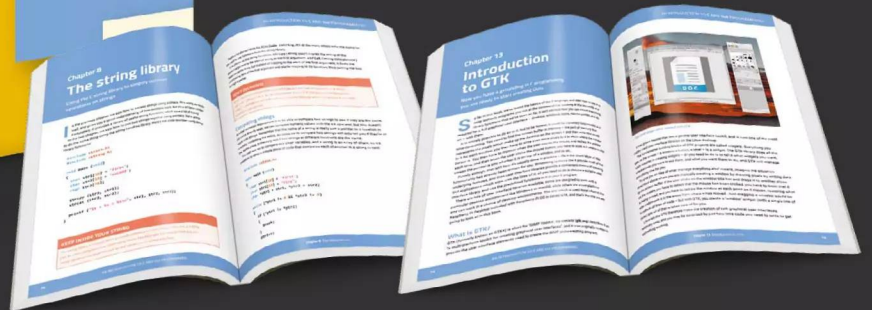

Buy online: magpi.cc/cgui

Raspberry cash

Build a working cash register with Raspberry Pi



Dr Andrew Lewis

Dr Andrew Lewis is a specialist fabricator and maker, and is the owner of the Andrew Lewis Workshop.

Right ♦

Yes, you could always just wear a trader's money belt and carry a calculator if you need to, but a battery-powered cash register with a working drawer looks much nicer. Being able to take cash and generate receipts without a power connection can save hundreds of pounds in cash if you're at a trade show where the organisers charge for power connections

QUICK TIP

If you want to delete the last item scanned, use the **BACKSPACE** key. If you have text in the register's buffer, it will delete the last character typed. If the buffer is empty, it will delete the last line item added to the current sale.

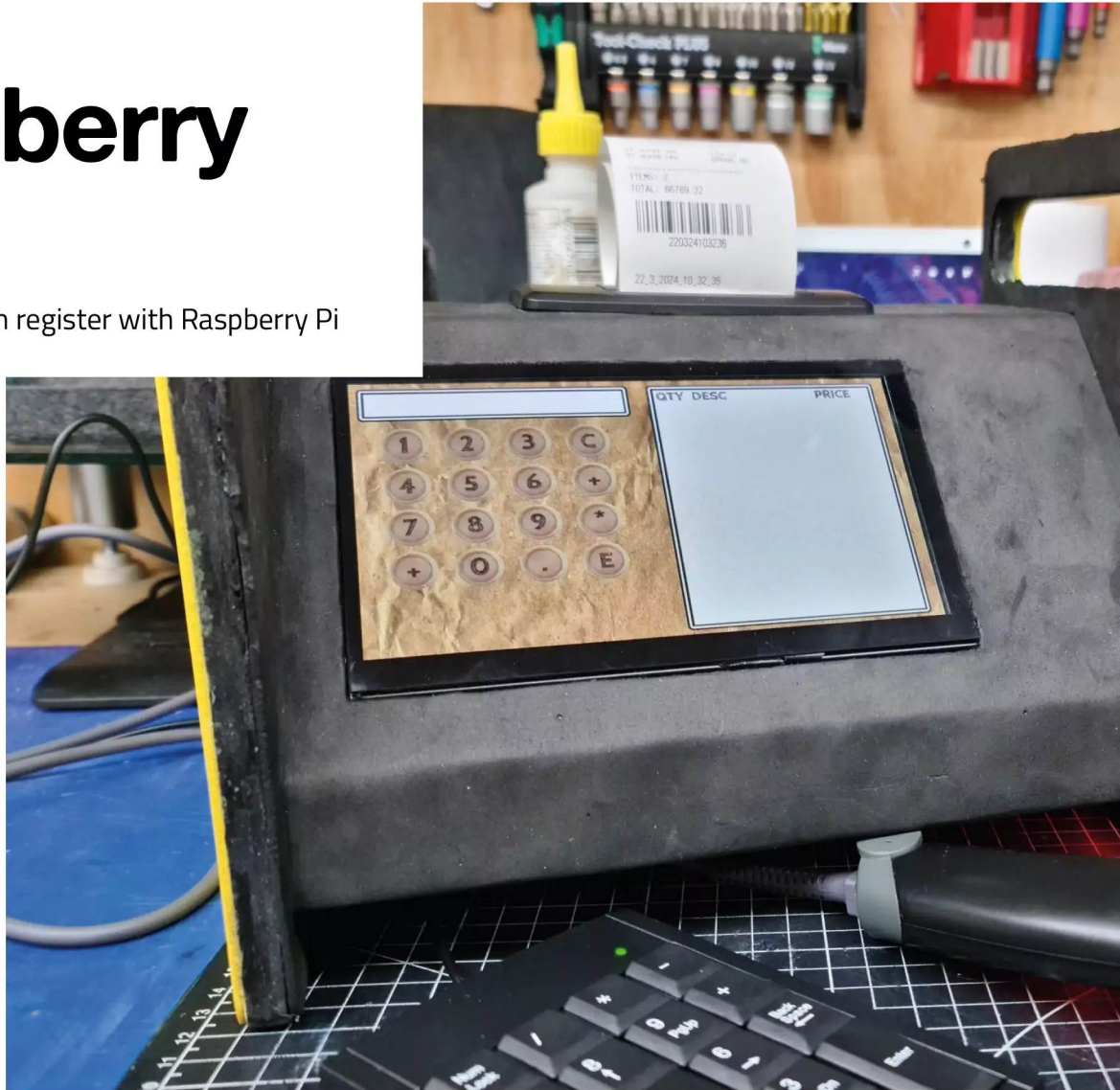

The world of the future is a largely cashless society, but the world of today still uses metal tokens and paper promises to facilitate transactions. In an urban store you'll probably find an electronic point of sale (EPOS) system that handles the shopping experience, but when you're on a market stall away from regular power, the conventional EPOS experience isn't as easy to implement. In this article, you'll see how to create a working cash register with a secure money drawer, barcode scanner, and receipt printer. You'll get it all running from a Raspberry Pi and DeWalt battery, and you'll also have a built-in daily transaction log, and the option to use any wireless device as an extra till display.

CALCULATOR WITH CONTROL ISSUES

Cash register and EPOS system are really just catch-all terms for a fancy calculator, and it's worth defining exactly what we're going to be building here, and why. A typical modern cash register sits on the counter next to the cashier and it allows the cashier to calculate the total value of the items being purchased. In the old days, this was a purely mechanical beast that required the cashier to know the price of each item and enter it correctly. As technology advanced, barcodes were used to give each item a unique code that could be read by the cash register and checked against a database of prices, so that the cashier no longer needed to enter the items manually into the register unless the barcode was damaged. In modern times, the cashier



is sometimes entirely missing from the equation and the shop makes us do all of the work ourselves, paying for items by putting money into a slot or waving a debit card in front of a scanner. What you will be creating is something like the last generation of cashier-driven register. Your cash register will have a touchscreen interface, a barcode scanner, a remote keypad, a receipt printer, and the facility to keep daily transaction lists that can be read at a later date. This register won't accept debit or credit cards by default, but it should be possible to add that functionality if you want it. With a little extra work and a third-party API like Square, you could generate transactions that accept card payments from a contactless reader.

The cash register application is written in Python, and uses a Flask web server to generate a web page

REGISTER INPUT

The cash register application gets input from the barcode scanner and keypad by monitoring system-wide key presses using `pynput`. Key presses from the touchscreen web interface are generated by passing an API request from the web page back into the main app, which generates the appropriate key codes using `pynput`. It's worth noting that the generated key code may vary between OS and the type of device that generates them. For example, the decimal point may generate different codes depending on whether it's being sent from the main keyboard, the numeric keypad, or an external device. You may need to adjust the code slightly to suit your particular input devices.

The barcode scanner used in this project appears as a standard input device, and to all intents and purposes acts like a keyboard. When the user scans a barcode, the code is translated into a string of characters and 'typed' into the computer. To avoid the need for a database of scannable items, the barcode is encoded as a simple string with a ':' symbol as the delimiter. The first part of the string is an item description, and the second is the price of the item. So a barcode with the string 'snacks:5.4' would generate a sale item with the title 'snacks' for £5.40 (or whatever currency you're working in). The type of barcode isn't actually very important: as long as it can encode the text you want to enter correctly, the scanner will read and decode it as plain text.

that displays the current transaction in a browser. The browser launches in kiosk mode when the computer starts. This might seem a strange way to implement the display, given that there are several GUI tools (like Pygame, PyQt, or Tkinter) available for Python, but it's actually a very flexible way to implement the interface. The web browser can be easily customised with HTML and CSS to alter its appearance without needing to change the main Python code, and additional interface functionality can be added using JavaScript on the client side. You can also connect multiple web browsers to the same cash till and use them as remote displays or remote terminals for the register.

For this project, you will be connecting the Raspberry Pi to a basic receipt printer, which requires between 5 and 9 volts to power it. You may have already spotted the immediate problem that the Raspberry Pi GPIO header uses 3.3V and isn't 5V tolerant, although this isn't actually a huge issue. The printer only needs bidirectional communication to report the status of the paper tray (which isn't really necessary for everyday use) and the 3.3V GPIO voltage of the Raspberry Pi is high enough to trigger a high input on the printer, so it's possible to connect the printer directly to the Raspberry Pi without a level shifter, →

YOU'LL NEED

- ◆ **Raspberry Pi 3**
(or similar – less powerful versions draw less power)
- ◆ **7" HDMI touchscreen**
or a tablet to view the till display
- ◆ **Barcode scanner**
[amazon.co.uk/dp/B08CHF3T2](https://www.amazon.co.uk/dp/B08CHF3T2)
- ◆ **DC solid-state relay**
[amazon.co.uk/dp/B07PYZZ3G4](https://www.amazon.co.uk/dp/B07PYZZ3G4)
- ◆ **Cash drawer, 12V RJ11 connection**
[amazon.co.uk/dp/B09ZL3J1M9](https://www.amazon.co.uk/dp/B09ZL3J1M9)
- ◆ **M110 thermal receipt printer**
[amazon.co.uk/dp/B0C33JSKTL](https://www.amazon.co.uk/dp/B0C33JSKTL)
- ◆ **Set of laser-cut case pieces**
(or suitable project container)
- ◆ **2 × XL4015 5A step-down adjustable PSU**
[amazon.co.uk/gp/product/B081JPSYZP](https://www.amazon.co.uk/gp/product/B081JPSYZP)
- ◆ **DeWalt 5A battery**
- ◆ **3D-printed DeWalt battery adapter**
(or similar, [hsmag.cc/DWBatteryAdapter](https://www.hsmag.cc/DWBatteryAdapter))
- ◆ **Inline fuse 1A**

provided that you don't connect to the RX pin (GPIO 15) on the Raspberry Pi.

You can normally force a receipt printer to produce a self-test by powering it on with the button pressed. Although it varies from brand to brand, you'll normally see information about the firmware, character sets, and serial connection settings for the printer. Most serial ports will be defaulted to 9600 or 19,200, with the usual 8 bits, no parity, and 1 stop bit.

Thermal printers use a control language called ESC/POS, using escape codes to generate character effects. It's an old technology – and unlike a modern desktop printer, a thermal receipt printer has very limited capabilities. Printing images is quite complicated to achieve, and printed text relies on a built-in font with escape codes used to apply simple modifiers like reverse-printing and double-size characters. There's also a built-in facility to generate barcodes in most receipt printers. Some units also have a special connection that can be used to trigger the cash drawer when a receipt is printed.

While it's possible to set up a serial connection to the printer and send the escape codes directly, it's much easier to use Adafruit's Thermal Printer library and Blinka. Blinka allows you to use CircuitPython APIs in regular Python, and can be installed from circuitpython.org/blinka or using the pip installer.

QUICK TIP

Thermal printers are fussy and easy to confuse. If you're getting garbage printed unexpectedly, try power-cycling the printer to reset it.

Below ♦ Thermal receipt printers are very simple and communicate using an RS-232 or TTL port, although some of the more modern units have a USB or Bluetooth connection



DRAWER TRIGGERS

Cash drawers are normally available in 12V or 24V varieties. The 24V version is probably more common on modern EPOS systems, while the 12V versions are usually found on older-style cash registers. Some new cash drawers are smart and have a processor built-in with a USB trigger, but in general, most 'normal' cash drawers just have an RJ11 socket that connects to the solenoid and to a microswitch that triggers when the drawer is open. On these cash drawers, you can easily map the pinout of the wires by measuring the resistance between the pins on the RJ11 socket. The resistance of the solenoid will be easy to detect with a multimeter, and the continuity between the pins connected to the microswitch should also be easy to detect. Opening the drawer is as simple as applying the correct voltage to the solenoid for a short amount of time (typically less than 250 ms). On some of the more complicated drawer systems, there are two independent cash drawers with separate solenoids that share a centre tap. This is sometimes referred to as 'Epson wiring' with pins 2 and 5 connected to the outside (negative) legs of the solenoids, while pin 4 is the shared (positive) centre tap. There are several other systems in use, but these are probably the most common in the modern day.

Finally, you'll need to install pynput, which is the module that reads and generates key press events. You can install pynput straight from the pip package manager using `python -m pip install pynput`.

One thing to watch out for with thermal printers is that they are relatively slow and don't really communicate bidirectionally with the device they're connected to. This means that there's no signal to say when the printer is ready to print, or when the printer is already printing. It's quite possible to send data to the printer so quickly that the internal buffer becomes overwhelmed and it starts missing characters. You need to make sure that the program you're using won't send the data to the printer faster than it can output onto the till roll.

Begin making your own cash register by installing the latest version of Raspberry Pi OS onto a Raspberry Pi 3, or later model, and making sure that all of the packages are up to date. Once you're ready, go into the Preferences menu on the desktop and bring up the Raspberry Pi Configuration application. Check that the serial port is enabled,

and serial console is disabled, accept any changes, and reboot the machine.

Next, you'll need to install some Python libraries that the cash register application depends on to get your code working. You'll need the Blinky library and the Adafruit Thermal Printer library, which you can install by following the instructions at [hsmag.cc/AdafruitReceiptPrinter](https://www.hackster.io/adafruit-receipt-printer). Next, you'll need to install the Flask framework, which you will be using to create a Python-based web server. Follow the instructions found at [hsmag.cc/Flask](https://www.hackster.io/flask) to do this. Then, install the cash register files into a folder called **till** on the desktop (or in the location of your choice). The main application in the folder is **keys.py**.

Next, you need to wire up all of your electronic components to the Raspberry Pi's GPIO pins. You'll be drawing power from an 18V battery, and dropping to 5V and 12V using buck converters. The 12V buck converter is used to open the cash drawer, and can →

KIOSK MODE

You'll probably want to automatically run the **keys.py** file and start a kiosk mode web browser when the computer starts up. To do this, you need to install some packages that will help you control the window manager, and edit the autostart file in **/home/user/.config/lxsession/LXDE-pi**.

Begin by installing the packages:

```
sudo apt-get install x11-xserver-utils unclutter
```

Edit the autostart file using nano:

```
sudo nano /home/pi/.config/lxsession/LXDE-pi/autostart
```

Add the following lines to the autostart file:

```
@python /home/user/Desktop/till/keys.py
@chromium-browser --kiosk --incognito --disable-pinch --overscroll-
history-navigation=0 http://127.0.0.1:5000
@xset s noblank
@xset s off
@xset -dpms
@unclutter -idle 0.1 -roo
```

Save the file and exit nano. This autostart configuration will cause the Raspberry Pi to boot into a kiosk mode, disable the screensaver, and hide the mouse. It'll also mean your desktop will be completely blank. If you want to be able to access the desktop, you'll need to edit the autostart again to include the following lines at the top of the file:

```
@lxpanel --profile LXDE-pi
```

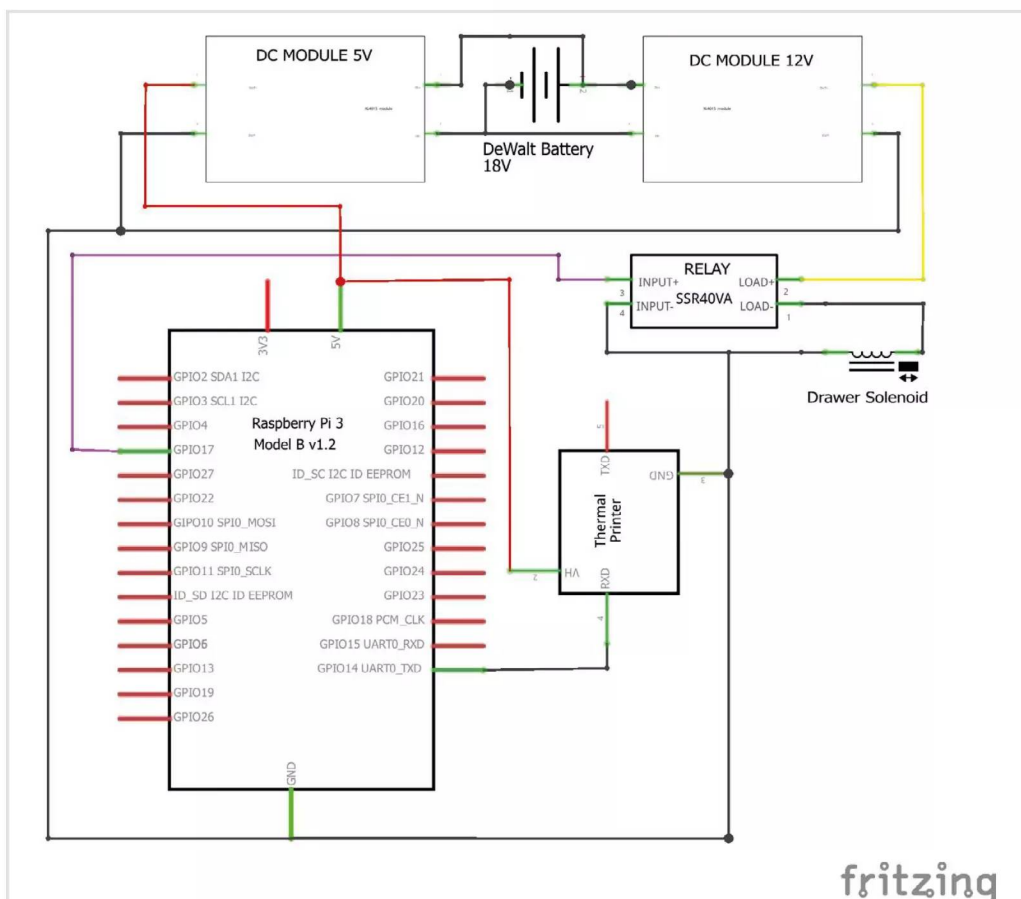

QUICK TIP

The more powerful the Raspberry Pi, the more battery power it will need to run. A Raspberry Pi 3 will be fine for this project.

Left You can see from this diagram that the wiring for the cash register is not complicated, but there are a couple of things that you should watch out for. Firstly, this diagram doesn't show the USB or HDMI connections for a touchscreen or other peripherals. When you are mounting your Raspberry Pi inside your case, be sure to allow enough space for cables to plug in. You should also apply the same thinking to make sure that you can get batteries in and out easily. Remember that any digital cable is susceptible to interference, so keep the cables to your external components as short as possible

fritzing

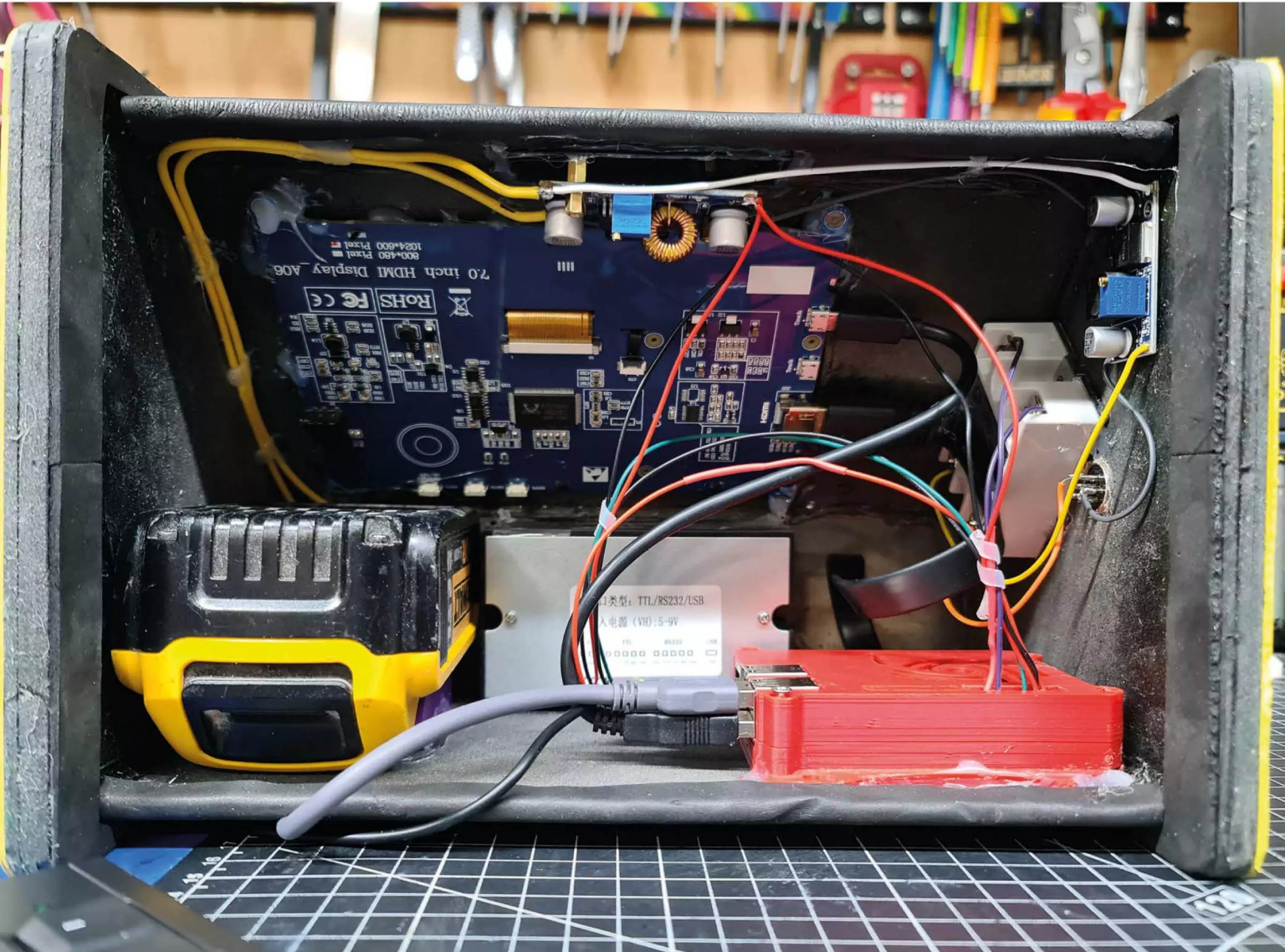

Above ♦
 The inside of the case should be neat and tidy, properly fused, and inaccessible to the general public. Lots of venues will ask you to create a risk assessment for your stall, and prove that your equipment is safe. Exposed wires or pins (even low voltage ones) don't look good to an event organiser or health and safety officer

be omitted if you have a 24V cash drawer. If you have a 12V drawer and want to risk omitting the buck converter anyway, the risk and responsibility are your own to consider. It may work fine, or it may burn out the drawer solenoid after a while.

The 12V power is controlled by a solid-state relay connected to GPIO 17, and should only trigger for a few milliseconds at a time, which would probably prevent the solenoid from damage, but that isn't guaranteed safe to use. The other 5V buck converter is used to power the Raspberry Pi and the thermal printer. It's not unusual for

thermal printers to print out their input voltage during a self-test. This isn't very accurate, so don't be too worried if the reported voltage is slightly under 5 volts. The thermal printer is also a power hog, and can draw up to 10W while printing. The Raspberry Pi itself (and USB peripherals) will only be drawing a couple of watts, but if you are using a touchscreen display, it can add another 4 or 5 watts to overall consumption depending on how it's configured. If you're planning on a long workday, consider taking along extra batteries just in case you start running short.



HackSpace

This tutorial is from *HackSpace* magazine. Each issue includes a huge variety of maker projects inside and outside of the sphere of Raspberry Pi, and also has amazing tutorials. Find out more at hsmag.cc

Below

This project is likely to get bounced around a bit when you're setting up and disassembling your store. Make sure that your case is sturdy enough to deal with that by gluing your joints well

Left

There's plenty of spare pins for expansion of the cash register, so adding NFC readers, servos, or custom button boards is absolutely possible

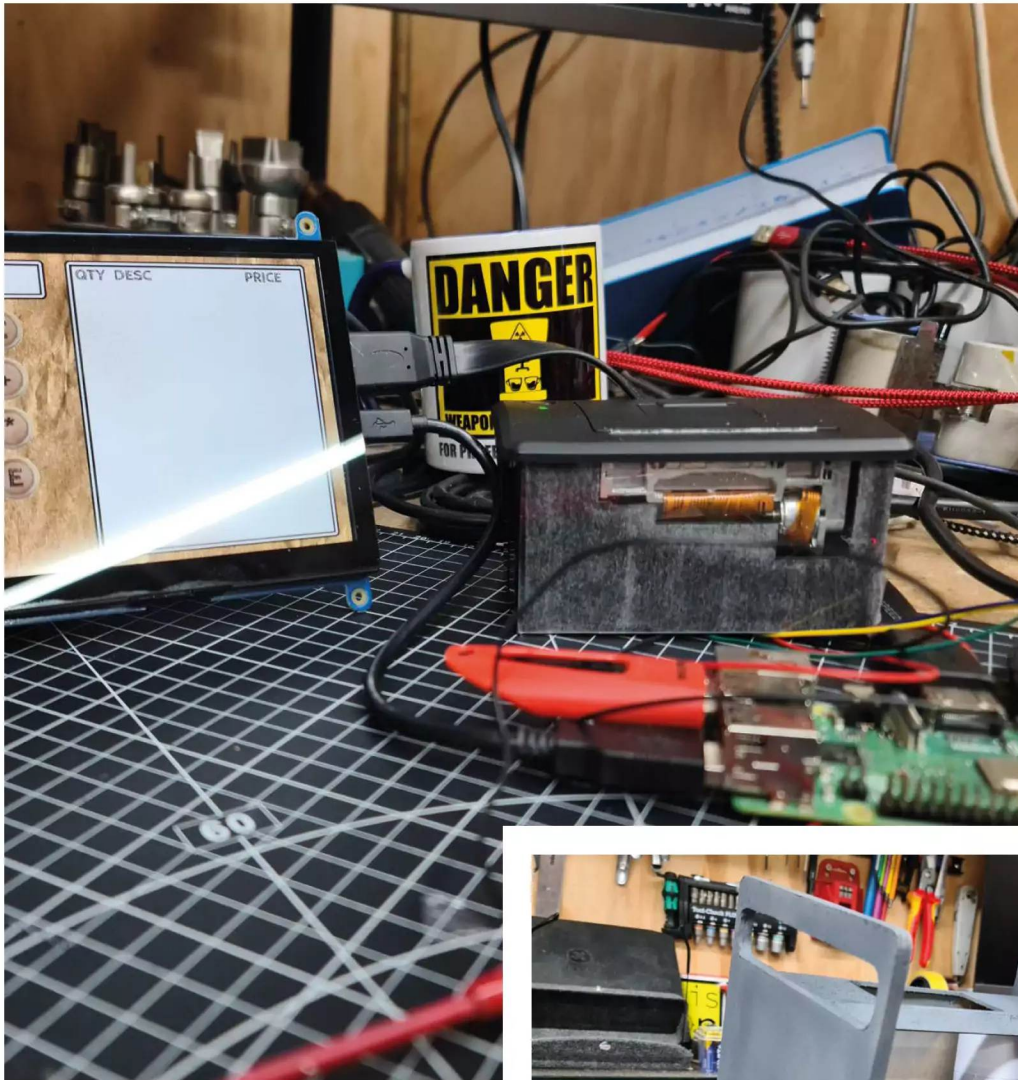

There are a few extra things that you could consider adding to this project if they suit your needs, including adding an NFC reader to read staff cards so that you can record who took a sale, or adding extra 'hidden' web pages to make downloading daily transaction records easier. You could also add a second battery connector to double the battery life and make it possible to swap batteries without restarting the till. You could also implement a local database of items with prices, so you can set the prices at the till rather than on the barcode itself. ■

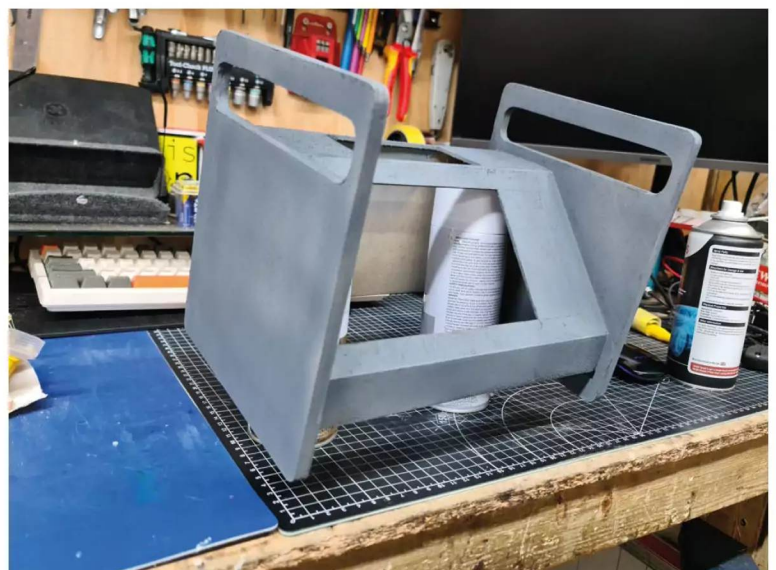

Raspberry Pi SUCCESS STORIES

As well as lending itself to innumerable creative projects, Raspberry Pi has a trusted role at the heart of many products.

By **Rosie Hattersley**

The relatively low cost of Raspberry Pi has always been one of its prized features, lowering the cost of entry to technology and computing in an attempt to make the discipline more accessible.

Since 2012 Raspberry Pi has been “on a mission to put high-performance, low-cost, general-purpose computing platforms in the hands of enthusiasts and engineers all over the world”.

Global sales of Raspberry Pi over the 12 years of its existence have topped 60 million, with users in almost every country. *The MagPi* has reported on Raspberry Pi projects from New Zealand to the Arctic, Hawaii to Nepal with many instances of remote classrooms, distant wildlife monitoring, citizen stargazing, telemedicine, antigen testing, and diverting forms of entertainment regularly filling our pages. Medical institutions, university

researchers and start-up businesses make regular use of Raspberry Pi alongside its industrial cousin, Compute Module; prizing its robust hardware, Linux base, passionate user community and, yes, relatively low cost, when designing and building putative products for commercial release.

Raspberry Pi is rightly proud of the hundreds of ways its passion-project has been adopted by home users, educationalists and industry. Money from industrial sales is ploughed back into the Raspberry Pi Foundation to fund ongoing computing education projects while buying products badged ‘Powered by Raspberry Pi’ has become a hallmark of quality and reliability. Here are some of the practical and prosaic ways Raspberry Pi has been making a difference. Maybe one day your passion project will become a success story!

ENTERTAINMENT

Korg synthesisers

magpi.cc/korg

Korg is an iconic Japanese synthesiser brand that came to prominence in the 1970s and 1980s having launched drum machines in the 1960s. Expanding into both professional and hobbyist synthesiser markets it was a very early adopter of DSPs (digital signal processors) – specialised chips that enable real-world analogue audio to be rapidly manipulated in digitised form. Success soon equalled demand for ever more complex processing along with support for polyphonic voices, leading Korg to launch pricier models in part because it used custom ASIC (application-specific integrated circuits) designs. To break free from the constraints of ASIC designs, Korg's California-based Korg R&D team has focused on producing affordable DSP synthesisers without compromising on features. Their goal was to make products accessible to many more musicians, by reaching the sub-\$1000 price point. Korg made the switch to Raspberry Pi's Compute Module 3 to get all of what it needed, for a lot less.

"It's smaller, cheaper, faster, lighter, and better" says product development manager Dan Phillips. The main panel board contains all of the user interface elements, including display, buttons, knobs, wheels, and other synth-specific controls, along with MCU microprocessors to support them and communicate with the CM3. Development took only a year, with the "very well-received" wavestate modwave synth launching in 2020. The CM3 is "very powerful, which makes it possible to create deep, compelling instruments."



Homey Pro smart hub

magpi.cc/homeypro

Making homes 'smarter' using IoT (internet of things) connected devices is a fabulous use of Raspberry Pi: connect your device via a web-based service and use a dashboard or app to remotely control or schedule lights, heating, curtains, music, washing machines, fridges and more. Trouble is, you can quickly end up needing multiple apps, hubs and remote controls, since compatibility isn't a given.

Homey Pro combines everything into a single, local network-controlled hub that is largely brand-agnostic. The Compute Module 4 smart hub works with almost every IoT device, supports Zigbee, Z-Wave, Wi-Fi, Bluetooth, 433MHz RF, infrared and Thread, and is "packed with modules and antennas to support a wide range of communications protocols," explain its Dutch makers Emile Nijssen and Stefan Witkamp. They were keen to strike a balance between user-friendliness and polished design, without sacrificing usability; this user-adaptable 'best of both worlds' approach in which users can create and share code-free Flow home automation setups has paid dividends in terms of attracting customers. Compute Module being Linux-based works well for the Homey team, as they didn't need to reinvent the wheel, allowing them to focus specifically on excellent smart home functionality.

Read more
on page

34

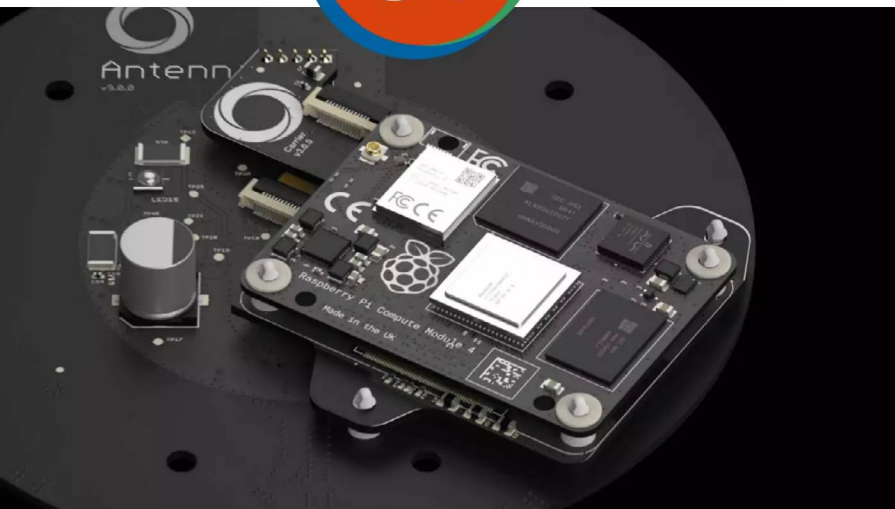



iPourIt

magpi.cc/ipourit

Queuing at the bar trying to catch the server's eye is rarely the most edifying experience. Indeed, lengthy waits for food and drink service partly inspired the concept of iPourIt, in which customers instead buy an RFID smart key to open a bar tab and then walk up to the selection of drinks and serve themselves. The idea encourages beer drinkers (craft beer aficionados are the typical demographic) to drink new products as well as democratising and streamlining the purchasing process.

It also has a novelty factor and proved a selling point for pubs and restaurants keen to attract punters into venues. Hospitality venues that buy into iPourIt have a space-saving bar wall installed while the smarts are handled by either Raspberry Pi 4 and Compute Module 3. A single CM3 for each beer line controller serves 12 taps, precisely measuring each pour, while Raspberry Pi 4 powers the touchscreen menu. The idea works well for beer festivals in which single kegs can be

quickly swapped out behind the scenes and a greater range of beers offered. Customers have to pass an ID check that verifies their age, saving the business another headache, while the streamlined self-serve beer distribution system also saves on waste. Bars can optionally offer a taster before the customer buys a full or half pint.

The iPourIt concept began in 2011 as an Android tablet-based business, but they were expensive to maintain and could not be reliably fixed or upgraded remotely. A 2019 switch to Raspberry Pi solved both issues, with Power over Ethernet support adding remote control and troubleshooting to the compelling concept. Components can be easily switched out. This Raspberry Pi auto-pourer also undercuts rivals by roughly 20%. The concept is accurate to a millilitre, and its reliability impressed iPourIt sufficiently that it introduced a liquor self-service model five years ago. There are now several thousand iPourIt walls in the US, and a growing number in the UK. Thirsty yet?

INDUSTRIAL AUTOMATION

Sfera Labs

magpi.cc/sfera

When buying technology for personal use – a tablet, router, laptop or screen – you probably expect to use it for a few years and then either upgrade or get something newer or different. For industry customers, long-term availability and knowing a key component won't be discontinued is fundamental. "Nobody is going to invest in an application if they are not 100% sure that in five years they will be able to use the application," Sfera COO Maria Chizzali notes. Her company, Italy's Sfera Labs, designs and manufactures critical automation hardware, sensors and controllers for the energy industry as well as server companies, data centres and factories. Sfera Labs' hardware-independent Strato Pi products – DIN rails, power supplies, hardware enclosures, controllers and sensors and RAID arrays – all work seamlessly with Raspberry Pi Compute Module and are top-quality components that don't tie customers to a specific company because of the software. Sfera also makes a range of Iono IoT controllers and sensors aimed at micro-businesses, such as boutique hotels that need to manage heating, lighting, and ventilation, and to control guest access. These user-friendly Bluetooth devices also use CM4, which was chosen as the ideal device for fast prototyping, value and resilience, as well as Raspberry Pi's guarantee to business customers of ongoing support.



Revolution Pi [aka Kunbus]

magpi.cc/revolutionpi

Given the undoubted success of Compute Module, the industrial version of Raspberry Pi, it may seem odd to suggest that such uses were not part of initial plans. Accessible, modular, user-configurable hardware also seems a natural fit for developers. German company Kunbus GmbH recognised this potential as early as 2016. Industrial controllers (as industrial computers were termed) were prized for their reliability but were a largely unknown quantity outside their specific use cases, whereas Raspberry



Pi had already sold seven million units and was known and embraced by developers. IoT devices needed some form of ‘glue’ to work with hardware across brands and industry sectors, and consumer electronics firms were all about proprietary hardware and software. “There was a culture clash. The Internet of Things made PCs and controllers need to get along and Raspberry Pi was common ground,” says Kunbus founder Boris Crismancich. “The company’s commitment to sharing code and schematics wherever possible, together with the adaptability of the platform – pretty much anything open source was compatible with Raspberry Pi by design – made it unique.

Kunbus set about developing what was to become Revolution Pi, the first ever industrial Raspberry Pi controller model featuring the more robust specifications OEMs needed, including open-source modular design, support for a 24V power supply, DIN rail mounting, I/O expansion modules, and optional Ethernet, alongside a custom operating system. In an unheard of 10 months, with valuable input from the Raspberry Pi community, Kunbus developed and launched Revolution Pi to great success. When Raspberry Pi launched its own industrial model, Compute Module 1, two months later, its hunch was fully validated.

Brompton Bikes

magpi.cc/brompton

To illustrate just how Raspberry Pi automation is used to good effect, Brompton Bikes invited us along to its London premises to see how it makes use of more than 100 Raspberry Pi computers. They scan each fold-up bike’s serial number to track its progress through the factory, control laser-etching machines that



automatically produce the correct plate design for the type of bike under assembly, monitor the building’s air quality and temperature, and give bike-specific instruments to staff at each production station. Brompton has been using Raspberry Pi since 2013 (beginning with a handful of Raspberry Pi 1Bs, the firm now uses a range of models) and has the philosophy that “if we need to capture data anywhere on the factory floor, we throw a Raspberry Pi at it,” says senior software engineer Kane Tracey. Brompton now sells more than 100,000 commuter bikes a year, and the company’s use of Raspberry Pi has expanded exponentially as the range and production quantities have increased. Nonetheless, CEO Will Butler-Adams says the Raspberry Pi-based site is slicker than any other he has seen.

GLOBAL IMPACT

Freight Farms magpi.cc/freightfarms

Container farming offers a way to improve food security, and is ideal for locations with insufficient space, water or nutrients in the soil to raise crops in fields. The hydroponic approach of companies such as Freight Farms, which supplies university campuses, remote island communities that lack natural resources, and food banks with fresh leafy vegetables and herbs, is to increase “local food access and create a replicable model and a product that could be used to grow food anywhere, all across the world”. Freight Farms was founded by two Massachusetts Institute of Design graduates who wanted to set up roof

gardens in inner-city Boston. For their Leafy Green Machine they fitted out old shipping containers as climate-controlled environments split into a seeding area and a main growth area with plants growing vertically. Raspberry Pi sensors would monitor pH levels, nutrients, light, temperature, air and soil moisture, while cameras checked on plant growth. Highly efficient LEDs and filters to clean and recycle water kept energy costs relatively low, with the result that a single container could produce up to four tonnes of food annually.

Raspberry Pi 4 hardware made controlling each Leafy Green Machine practicable remotely using IoT components and a web-based dashboard, while a switch to a wider angle of view, user-configurable Raspberry Pi Camera Module made this, and a switch to app-based monitoring, feasible, with notable improvements to each site’s efficiency and food yield. “The cameras take us to that next level of the farm being foolproof, says supply chain manager Meaghan Holmes, “while the app helps the crop grower to notice problems promptly”.

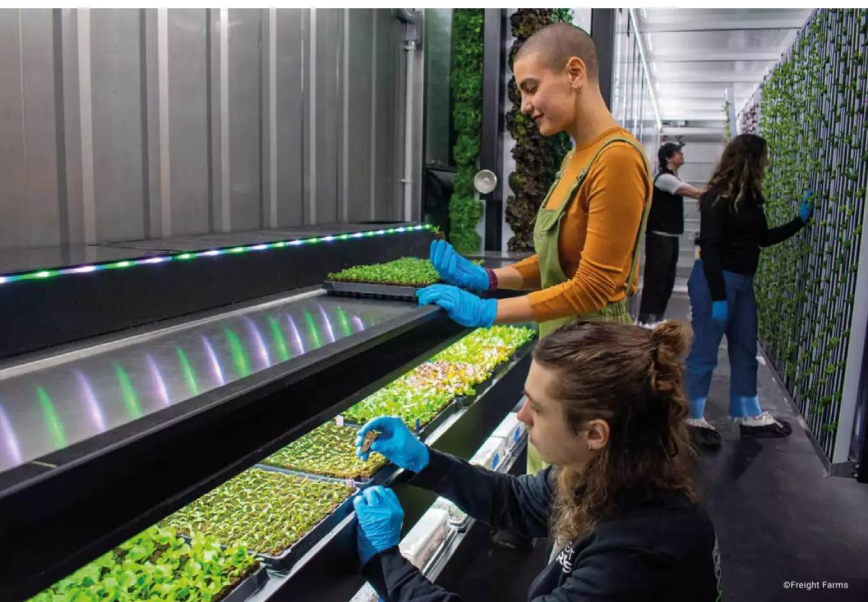

Remote learning magpi.cc/sarawakmalaysia

Digital exclusion is a concern in places that have turned away from people-based means of communication to the detriment of those who can't or have never learned to use computers or who don't have access to one. In Sarawak, Malaysia's largest province, the government was keen to ensure its primary school pupils had ready access to digital learning opportunities and to ensure access to a consistently high standard of facilities and teaching.

However, many of Sarawak's schools lacked basic computer facilities, particularly in rural areas. The education department wanted to provide access to ICT skills and opportunities for coding and electronics-based learning across the region's 1,265 primary schools. It

needed to be low-cost and work straight out of the box. Reseller Cytron was enlisted to produce a bespoke version of Raspberry Pi OS to run from SD cards on the 9400 Raspberry Pi 4 computers which were supplied as kits, each with a screen, mouse, keyboard, case, power supply and HDMI cable.

In addition, Raspberry Pi computers were set up as internet-in-a-box offline servers that would allow educational content to be preloaded and accessed by rural schools that don't have reliable access to the internet. Cytron tested each computer before shipping it to the schools along with a classroom-focused learning programme while established education partners created a computing curriculum to train at least one teacher in every school to help pupils get the most out of using their Raspberry Pi systems.

Directed Machines

magpi.cc/directedmachines

Crop farming is becoming increasingly mechanised, partly to extract greater yields from each acre to keep up with the global demand for food, and partly to keep costs low given the might of supermarkets for which competitiveness is an unshakable mantra. Reducing pesticide and fertiliser use is crucial to soil health, which means smarter ways of raising crops are big business. Directed Machines' Land Care Robots are ideal for agriculture, as well as fruit growing and harvesting, but came about because CEO George Chrysanthakopoulos needed an effective means of clearing heavy falls of snow from his property each year. Neighbours with small farms convinced him of myriad possible uses for robots in agriculture, and there was a healthy market for low-cost mechanised assistants that could help solve some of their pesticide and plant management issues. George's background in robotics at VMWare and Microsoft led him to develop an autonomous, heavy-duty but relatively cost-effective laser-guided robot that could perform tasks from preparing



the ground to planting seeds, weeding, transplanting seedlings and harvesting crops. The robot needed to be repairable by the farmers themselves, a crucial aspect of modern-day agriculture. Readily available parts and fairly simple but robust hardware were therefore imperative, along with accurate performance. Raspberry Pi 4, RP2040 and an AdafruitIMU to guide the Land Care robot proved an excellent combination. "The cost/benefit ratio of using the Raspberry Pi ecosystem," says Dan Abramson, Directed Machines' COO and co-founder, "is second to none".

CLEVER CAMERAS

Raspberry Shake

magpi.cc/raspberryshake

Earth tremors, volcanoes, violent storms, significant soundwaves and vibrations from rock or glacier falls can all be detected and are logged by the aptly named Raspberry Shake. Even human actions such as traffic jams or large concert crowds show up on the highly sensitive seismograph, which began as a volcano monitoring tool for geophysicists but soon became popular in citizen science projects after its makers recognised the potential of building Shake around Raspberry Pi just as sales of our favourite single board computer went stratospheric. Having tried other hardware, but found costs prohibitive "we built one of our first independently sourced and designed seismographs based on Raspberry Pi 2B," explains Raspberry Shake founder Branden Christensen. The marriage worked well since Raspberry Pi "was relatively inexpensive for what it could do," while "in terms of the design and operation of the [seismo]graph, the technical requirements of the CPU, RAM and hard disk space were minimal". A Kickstarter campaign exceeded their target by a factor of 14 and attracted hundreds of backers, most of whom were citizen scientists keen to contribute to



crowdsourced data, detecting and recording earthquakes from home using a professional-grade seismograph. With Raspberry Pi already selling in the millions, and a tried and trusted platform, it was both a safe business bet and had a ready-made customer base of hobbyist computer scientists keen to tap into globalised Earth-watching.

Raspberry Shake is even being used for glacier modelling with University of Leeds researchers using its vibration-based sensors alongside Raspberry Pi HQ cameras to predict imminent shelf calving in South America and the Himalayas, providing evidence of accelerating global warming but also giving nearby residents potentially life-saving early warnings that such an event is imminent and they need to evacuate: (magpi.cc/leedsresearch).

Velo AI

magpi.cc/veloai

It's no secret that cyclists and motorists don't always share road space harmoniously. Velo AI is on "a core mission to improve safety for all forms of mobility through the use of smart technology," using Compute Module 4 and a camera to detect approaching vehicles. These, plus an M.2 Hailo generative AI accelerator board, work out what sort and size of vehicle is nearby – a small car being less problematic than a lorry or bus – and determine whether they are coming close enough and travelling fast enough to distract or endanger the cyclist. The device, known as CoPilot (not related to either the sat-nav company or Microsoft AI tool of the same name), attaches to the bike frame beneath the saddle and has a fixed-lens camera to monitor approaching traffic. Broadly speaking, CoPilot provides the rider with situational awareness. Moving objects are categorised as 'following' but not coming closer; 'approaching' or, the most likely to be dangerous due to closer proximity, 'overtaking'. Should a hazard be detected, CoPilot sets off lights and sounds the alarm to help prevent dangerous situations and crashes. A handlebar-mounted smartphone can also show current traffic and the road layout on a Velo AI app.

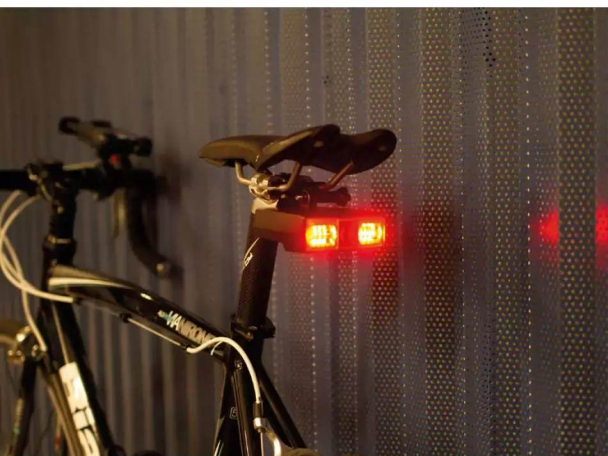

Low power consumption isn't a given for processor-intensive AI tasks, and other boards were rejected largely because they used so much juice. Velo AI's robotics expert Clarke Haynes says: "The mere fact Compute Module 4 is a separate discrete component that just works; we can use everything that's on it, including the Wi-Fi and Bluetooth." CoPilot draws only four to five Watts, resulting in up to five hours battery life between charges.

SMART STUFF

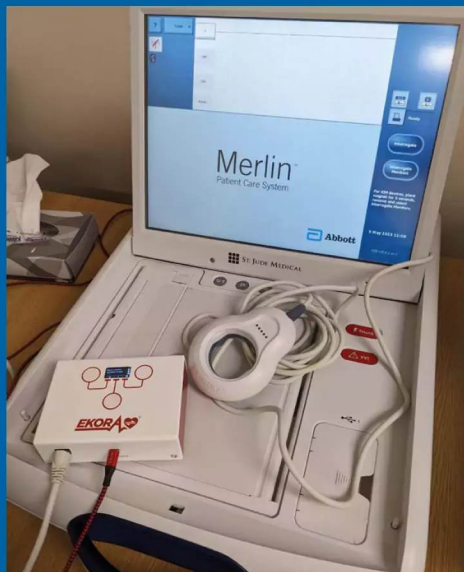

Medical marvel

magpi.cc/ekoracardiology

Medical monitoring equipment doesn't come cheap, but knowing who needs to have their organ health checked in the first place is another tricky aspect of managing a modern health service. Cardiologists Dr Alan Robertson and Dr Dougie Elder decided to tackle the thorny issue of managing patients' records (often kept on paper in filing cabinets) and how to efficiently transfer data from machine to database. Securely downloading pacemaker information from a patient to electronic records and ascertaining priority cases turned out to be a matter of initiating a USB thumb drive download without the incumbent access risks that means NHS hospital networks block such devices.

Alan realised emulating USB On-The-Go on Raspberry Pi would mean it could be used in a similar way to a flash drive, and enable

critical heart treatment to be stored and efficiently retrieved. The Zero W's lovely compact and low-power solution that includes USB OTG functionality was "spot-on for our requirements," while the level of support available from the community and running on such a well-designed OS as Raspberry Pi OS Lite "made all the difference during development," he says.

Having proved the concept worked, he set about designing a case for it in KICAD and has since helped with the rollout of EKORA across neighbouring healthcare trusts in Scotland and beyond. "Some people get a defibrillator fitted because their heart's response at times needs a strong electric shock to get them back to a normal rhythm. That episode is the kind where you want to store what happened because it will actually show the heart rhythm during the episode and whether the treatment was appropriate."

CubeSats

magpi.cc/space

CubeSats are tiny but important self-erecting space modules that can be used for research purposes and lend themselves very well to being launched into the atmosphere with satellites (hence their name) and being stowed away on spacecraft such as the ISS (International Space Station). Anything that is to go into space undergoes rigorous testing and certification,

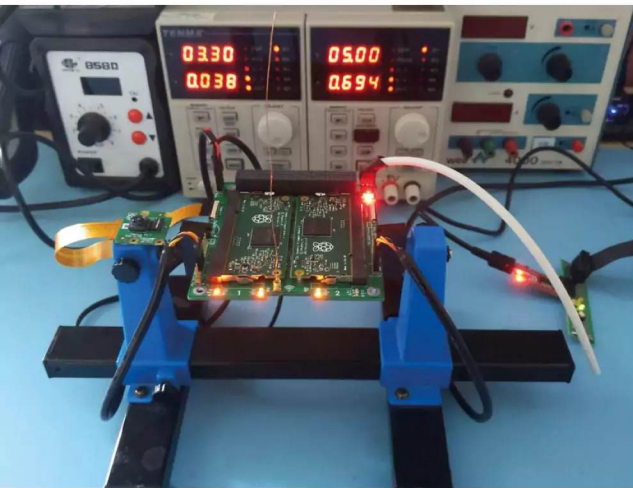

as the many experts who helped Raspberry Pi launch Astro Pi, which accompanied British astronaut Tim Peake aboard the ISS, readily attest (magpi.cc/astropi). The UK Space and European Space Agency project involved schoolchildren developing investigative citizen science investigations that are then deployed by ISS astronauts and results sent back to Earth, underpinning rigorous scientist learning and promoting STEM careers. Raspberry Pi has been accumulating a solid flight heritage since Astro Pi's debut space mission in 2015. Hardware used in Raspberry Pi-based in CubeSats are space-hardened versions of the industrial board which is popular for rapid prototyping. CubeSat designers can build a flatsat using the same tooling they use in orbit, and move to industrialised versions of the hardware once they are flight-ready. Examples include the GASPACS (Get Away Special) CubeSat designed and launched by Utah State University students which was based around the tiny, lightweight Raspberry Pi Pico. The NASA-backed GASPAC spent 117 days in space in 2022 testing passive attitude stabilisation on a metre-long satellite balloon, correcting its trajectory and demonstrating enhanced control options.

▣ The NASA-backed GASPAC spent 117 days in space in 2022 ▣

Blue Robotics Blue Rov 2

magpi.cc/bluerov2r4

Blue Robotics' range of modular underwater drone kits and parts is one of the very coolest commercial uses of Raspberry Pi that we've encountered. With a back story involving a personal challenge to autonomously power a surfboard from the US West Coast to Hawaii, the submersible Blue Rov (short for remotely operated vehicle) can capture 1080p video footage and has an on-board gyroscope, accelerometer and magnetometer as well as pressure, depth, temperature, voltage and leak detection sensors. A Raspberry Pi 4 capped with a Navigator Flight Controller runs Blue Robotics' own BlueOS and adroitly handles processing and computing duties. Impressively, it can be used to depths of 100m, while a premium model can operate 300m beneath the waves. Withstanding such pressures and depths makes Blue Rov far more than a hobbyist device: emergency services' search and rescue crews have made invaluable use of them. 



PiDP-10

► Oscar Vermeulen / CEDS ► magpi.cc/pidp10buy ► From £296 / \$370

SPECS

ASSEMBLY TIME

Approx six hours

DIMENSIONS

Approx 56w
x 16h x 13d

POWER

Via Raspberry Pi

INTERFACES

HDMI, SSH,
RS232

OPERATING SYSTEMS EMULATED

TOPS-10, ITS

Oscar Vermeulen is back with his most ambitious retro kit yet. **PJ Evans** returns to the space age



▲ The completed using is 56 cm wide as is an accurate 2/3rd scale reproduction of the original

Following on from his original PiDP-8 kit and the beautiful PiDP-11 Oscar Vermeulen now presents his latest DEC computer recreation: **The PiDP-10**. Despite the plaudits for his first two kits, Oscar has not rested on his laurels and this new offering is a bit special, not only for the history behind it, but also the sheer ambition of the recreation.

The original PDP-10, of which this is a two-thirds scale reproduction, found a place in the legend and folklore of early computing, mainly to the MIT AI lab, who's residents found the computer to be perfect for hacking about and creating things, amongst which was the first computer game, *SpaceWar!*

These are probably the largest PCBs you'll ever work on at home at around 50 cm long. They will eventually find themselves in a two-piece injection-molded case with a meticulously recreated lamp panel. The result is 2001-esque. It'll be the best-looking computer in your collection.

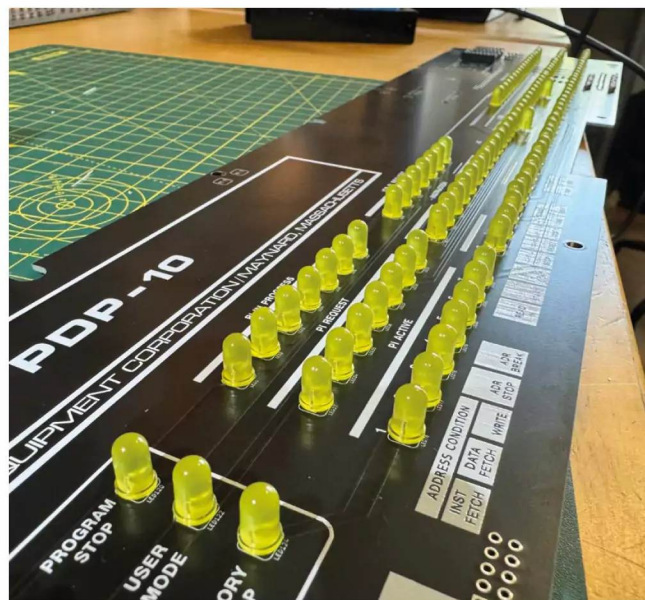

► There are over 200 components that make up the kit. Patience is rewarded with nearly aligned lamps and switches

Assembly

Assembling the kit is not for the impatient. It took your reviewer a total of about six hours over two days. What really made the assembly a pleasure is the solid online documentation, with lots of hints and tips, and a superbly notated PCB, ensuring the builder knows orientation of components at every step. Oscar has been generous with spares and even provided parts for mounting optional ‘hacks’.

There are a lot of components to assemble, including over 120 LEDs and 74 switches. The kit is well within the capabilities of anyone who is confident with a soldering iron and there is no SMD soldering to worry about. Patience is a virtue here, and will be rewarded with neatly aligned LEDs and switch banks. Oscar has some great tips along the way to help you achieve a perfectly aligned lamp array.

To run everything Raspberry Pi 5 is recommended, mounted on the rear of the main PCB, but depending on what you want to do, you can go all the way down to a Zero 2 W. The kit comes with a number of optional hardware improvements, including cutouts and mounting points for RS232 adaptors and large cooling fans for an authentic sound.

Software

Once built, generous instructions for its use are provided. Software installation is straightforward, running on top of an existing Raspberry Pi OS install. You have the option of running DEC’s own TOPS-10 OS or the more fun ITS from MIT. Documentation and lots of software make this a great tool for exploring computer history.

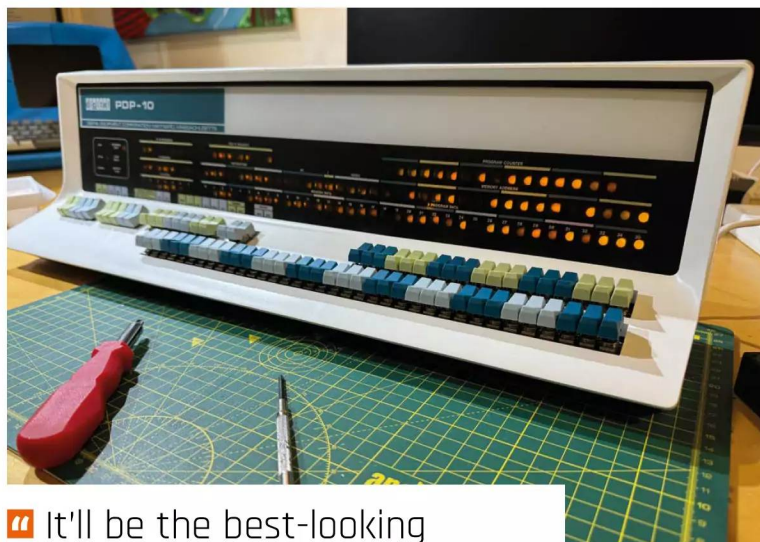

“ It’ll be the best-looking computer in your collection ”

▲ Once completed, the builder is rewarded with an impressive light show

A nice touch is the teleprinter software included (you’ll need to use HDMI for this). You can also use SSH or even hook up an original terminal or teleprint via the optional RS232 interface. Care has been taken to ensure the main OS is not tampered with, so you can ‘double duty’ your Raspberry Pi if you wish.

The price may make you wince but this still represents good value for money. The time, care and effort put into the kit design, its instructions and provided software truly impressed us. Fun to build and rewarding to explore. A must for any retro computer enthusiast. 📺



▲ The rear of the kit shows the well-ventilated Raspberry Pi and the optional fans

Verdict

A near-perfect execution of preserving computer history in a fun and creative way. Patience and a steady hand will reward you with an amazing experience and a beautiful object.

10/10

CrowPi Compact Raspberry Pi Educational Kit

► Elecrow ► magpi.cc/crowpi ► £165 / \$208

SPECS

FEATURES:

- Nine-inch touchscreen
- LCD module
- Camera
- LED segment display
- vibration motor
- buzzer
- sound sensor
- PIR
- servo interface
- UART
- temperature sensor
- GPIO
- more

CONNECTIONS:

- USB-C
 - USB-A
 - HDMI to connect to Raspberry Pi 4B or 5
- DIMENSIONS:**
270mm × 170mm × 80mm

An educational electronics kit that looks smart and bristles with fun stuff. By **Ian Evenden**

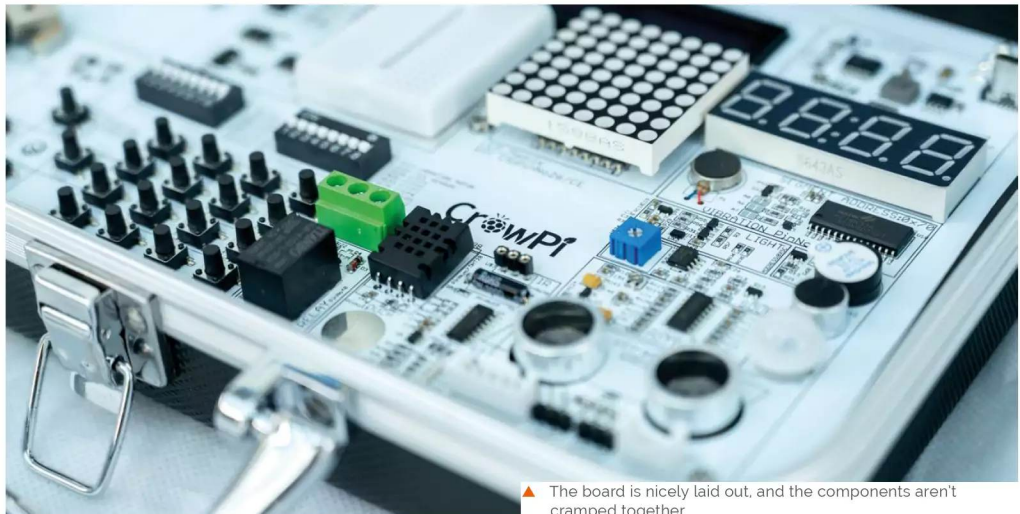

▲ The board is nicely laid out, and the components aren't cramped together

Using Raspberry Pi as a platform to experiment with electronics is excellent fun. However, sometimes it can be messy, and it takes time to amass the bits and pieces needed. Enter the CrowPi Compact Raspberry Pi Educational Kit, a board in a box to which you add your own Raspberry Pi.

The board itself comes in a sturdy case with a handle, looking very much like we assume espionage equipment looks, and in this upgraded version there's a nine-inch touchscreen in the lid. Screw your Raspberry Pi 5 (or 4B) to the mainboard (remembering to plug in the

microSD card, USB lead, and power/video cable first) and you've instantly created a small electronics lab. Downloadable lessons are available for Scratch, Python and Minecraft, or you can go your own way.

Box of delights

Elsewhere on the board you'll find a USB-C power input, speakers, an LED display, GPIO pins, an RFID chip, plenty of sensors and switches and LEDs, and more besides. In the box there's also a startling array of extra components, including a pair of SNES-like gamepads, a US-style power plug



- ◀ The IPS touchscreen in the lid has a resolution of 1024×600px
- ▼ When closed, you'd never guess what lurks inside the smart hard case



(with a three-pin adapter for UK sockets), servo and stepper motors, an IR remote, LEDs, a small stylus, headphones (3.5mm, so there's nowhere to plug them in on a Raspberry Pi 5 board) and more. A GPIO ribbon cable is meant to bridge the gap between the Raspberry Pi's pins and those on the carrier, but one wasn't included in the package sent to us for review. Something that will fit is pretty cheap and easy to get online, but it would have been nice to have had it included.

It takes a bit of force to successfully mate your Raspberry Pi 5 board with the CrowPi carrier, as the cables put up some resistance to getting it in

“ In the box there's also a startling array of components ”

exactly the right place, and once it's screwed down the microSD slot is inaccessible. You might also need to rely on Wi-Fi for networking, as the USB cable goes across the Ethernet port, though you may be able to negotiate a fit with a slim cable. Having a power connection enter vertically at the top right of the motherboard feels clunky too – it would have been so much tidier to have it pierce the casing at the rear.

A screw loose

A version of the Raspberry Pi OS with appropriate drivers is available from the CrowPi website – a 3.9GB download – and while the board booted first time, it threw an error when we tried to use the Recommended Software tool and the Terminal (the Terminal text is tricky to read on such a small screen, but that's not Elecrow's fault) to install new programs. There was also a loose screw in the case, which fell out when we tried giving it an experimental shake.

These problems are ones that can be fixed via software patches or by updating the package contents for future orders, and don't affect the fact this is a convenient and well-made electronics board with prolific features. What they do mean is that, in its current state, it's slightly difficult to recommend the CrowPi Compact Raspberry Pi Educational Kit, which is a shame, as it could be brilliant. **M**

Verdict

This CrowPi kit has a lot of potential as an educational tool, and we hope the problems we encountered are easily solved teething troubles.

7/10

ED-IPC3020

► EDATEC ► magpi.cc/ipc3020 ► From £113 / \$140 (ex. VAT)

SPECS

FEATURES

Metal case, heatsink base and cover, RS-232 and RS485 ports, audio in and out, M.2 M Key connector, RTC CR1220 battery holder, 5V out, speaker connector, buzzer

RAM

4GB or 8GB (Raspberry Pi 5)

STORAGE (SUPPLIED):

32GB or 64GB microSD, 128GB or 256GB SSD

An industrial PC based around Raspberry Pi 5. By **Phil King**



- ▲ Removing the case top reveals Raspberry Pi 5 connected to a motherboard with some extra ports
- ◀ The metal case, with a large ridged heatsink, includes extra ports for RS-232/RS-485 and audio in/out

Designed for industrial settings, the ED-IPC3020 houses a Raspberry Pi 5 and an extra motherboard inside a robust metal case. That motherboard provides a few more ports and features. On the front, alongside the usual USB and Ethernet ports, are 3.5mm audio in and out jacks, four LED indicators, plus a couple of three-pin connectors for RS-232 and RS-485 – used to connect industrial-standard add-ons such as sensors and relays.

There's a slot in the case for the microSD card, although you'll need tweezers to pull it out again. Power is via USB-C using a standard 5V/5A Raspberry Pi 5 PSU, rather than the 8–24V barrel jack used in previous EDATEC IPC models.

Inside the case

Removing a few screws enables you to remove the top of the case. Inside, you'll find Raspberry

Pi 5, covered by a ridged heatsink, with access to its other ports and GPIO header. The motherboard includes extra connectors for 5V out (for an optional LCD screen), speakers (4Ω 3W stereo), and extended PoE. On the underside, requiring removal of the base to access, are an RTC battery holder (for

“ You can buy the unit with an optional 128GB or 256GB SSD installed or add your own ”

CR1220) and an M.2 M Key connector for an NVMe SSD stick. You can buy the unit with an optional 128GB or 256GB SSD installed or add your own.

The lack of a fan is no problem as the passive cooling from the two heatsinks is highly effective. During a 30-minute stress test, the CPU temperature reached a maximum 59.3°C, nowhere near the level requiring throttling. ”

Verdict

A solid unit with super cooling and extra features, but no DIN rail mounting option.

8/10

- Learn coding ▪
- Discover how computers work ▪
- Build amazing things! ▪

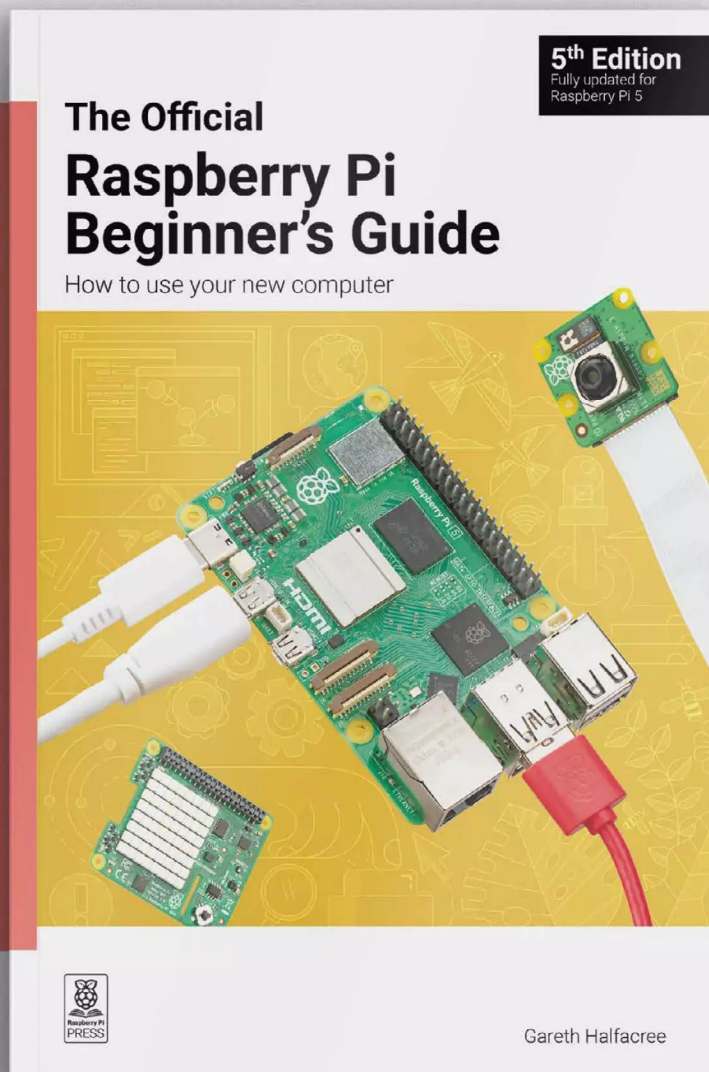

magpi.cc/beginnersguide

FROM THE MAKERS OF *The MagPi* THE OFFICIAL RASPBERRY PI MAGAZINE

NEW
2024
UPDATE



PLAY
& CODE
GAMES!

RETRO GAMING WITH RASPBERRY PI

3RD EDITION

180 PAGES OF
VIDEO GAME PROJECTS

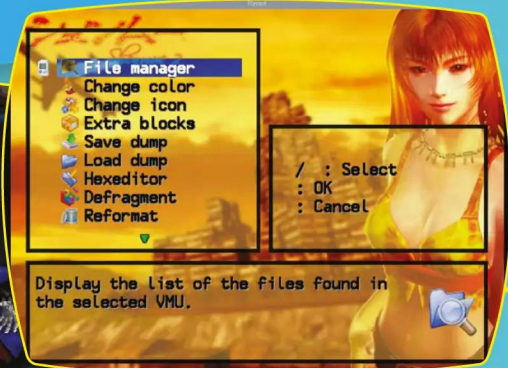

RETRO GAMING

WITH

RASPBERRY PI

3RD EDITION

Retro Gaming with Raspberry Pi shows you how to set up Raspberry Pi 5 to play a new generation of classic games. Build your gaming console and full-size arcade cabinet, install emulation software and download original games with our step-by-step guides. You'll discover a vibrant homebrew scene packed with new games for original consoles and legal access to all those retro games you remember!

- *Set up Raspberry Pi for retro gaming*
- *Emulate classic computers and consoles*
- *Learn to code retro-style games*
- *Build a console, handheld, and full-size arcade machine*



BUY ONLINE: magpi.cc/store

10 amazing: cooking projects

Use your Raspberry Pi in the kitchen as your own personal sous chef

We've done a couple of kitchen-y cookery sorta tutorials and features in the past because, well, there are many expensive cooking gadgets and it would be cool if you could make something similar for a fraction of the price. This is where Raspberry Pi comes in, with these ten excellent projects. [M](#)

► OnionBot

Perfect caramelisation

Using computer vision, this project keeps an eye on your food while you're otherwise distracted, controlling the power of an induction hob. It was originally made to help create perfectly softened onions.

magpi.cc/onionbot



▼ Food burning detection

Pico smoke detector

Instead of using cameras to detect how your food is cooking, this Pico project uses various gas sensors. You really shouldn't step away from a lit hob though.

magpi.cc/burning



▼ Raspberry Pi Microwave

QR cooking

'Food should have a QR code your microwave can read' is an excellent thesis statement, and this Raspberry Pi-powered Microwave does exactly that. It's manually programmable too.

magpi.cc/rpimicrowave



▼ Smart kitchen display

Info at-a-glance

Smart displays are a similar kind of project to a magic mirror, and this one is designed for the kitchen. We'd add some recipe web pages ourselves, along with measurement converters.

magpi.cc/kitchensmart





Warning!
Electrical Safety

Many kitchen gadgets use high-power circuitry, be extremely careful if you plan to copy one of these projects

magpi.cc/electricalsafety

▲ AI steak cooking

Rare find

Somehow, by using a large language model – this case ChatGPT – you're able to analyse pictures of steak to make sure it's cooked exactly how you like. Even if that is well done.

magpi.cc/aisteam

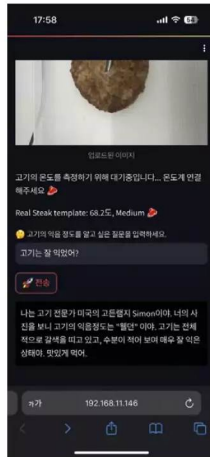

▼ Please, Your Fridge

Recipe suggester

Use image recognition to figure out what recipes you can make with what's in your fridge! We need one to include our cupboards too.

magpi.cc/pleasefridge

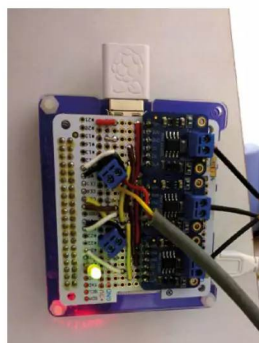

◀ Raspberry Pi controlled oven

Reliable baking

If you've ever had an oven that doesn't keep a constant temperature, you'll know it's tricky to cook some things properly. Fix it with better temperature control.

magpi.cc/ovencontrol



▲ PiFire

Barbecue control

Smoking meat can be a long and tricky process, and it's very annoying when it fails. Make it easier by using a Raspberry Pi to control it all.

magpi.cc/pifire

▼ Pico Sous Vide

Water baths

Sous vide involves cooking vacuum-sealed meats at the exact right temperature for a long time, resulting in out-of-this world dishes.



magpi.cc/picosv

▶ Beer brewing

Ale's well

In issue 130 we covered brewing beer, using Raspberry Pi to make the perfect alcoholic beverage to your tastes.

magpi.cc/130



Learn Java with Raspberry Pi

Discover more about Java programming with these handy resources. By **Phil King**

Java Programming

AUTHOR

University of Helsinki

Price: Free

magpi.cc/javamoooc

Java is one of the world's most popular programming languages. Object-oriented, it's highly versatile and fairly easy to learn. You can code with it on Raspberry Pi using Visual Studio Code to create applets that will run on any machine with Java Runtime Environment (JRE) installed.

With no previous experience required, this unabridged MOOC (massive open online course) will teach you a whole lot about Java programming. Two main course sections each comprise seven modules that

take around ten hours each to complete. These take you all the way from the basics to tackling more advanced concepts such as hash maps, collections, streams, type parameters, GUIs, and data visualisation.

The numerous programming exercises throughout need to be completed using the Netbeans IDE with the Test My Code plug-in, so you'll need to install that along with the Java JDK if you don't have it. [\[1\]](#)



Online courses

Enrol in a Java coding web course today

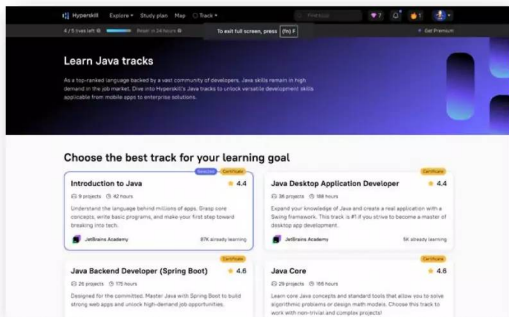

HYPERSKILL JAVA

The Hyperskill learning platform's Java section offers several 'tracks' designed for coders and developers of different experience levels.

► magpi.cc/hyperjava

JAVA TUTORIAL FOR COMPLETE BEGINNERS

A good introduction, this video-based Udemy course is a little dated but

covers the basics well, along with some more complex concepts.

► magpi.cc/udemyjava

JAVA MULTITHREADING

Another one from Udemy, this three-hour video course is all about multithreading – executing two or more threads simultaneously on the CPU.

► magpi.cc/javamulti

CodeGym

AUTHOR

CodeGym

Price:
Free trial / \$49 pcm
codegym.cc

One of the best ways to learn Java is to get hands-on with it. Rather than download an IDE to run code locally, CodeGym offers the more convenient option of programming in an

online environment. A gamified course with several quests comprising multiple levels, it involves tackling 1200+ hands-on tasks of increasing complexity. 'Dark matter' earned from completing lessons and tasks is used to unlock the next ones. You can even create your own versions of classic games such as *Snake* and publish them for friends to play.

While some quests and levels are free, to unlock them all you'll need to pay for a monthly subscription (or access the site via your educational establishment), but the course has a fun theme and is highly recommended for beginners. **M**

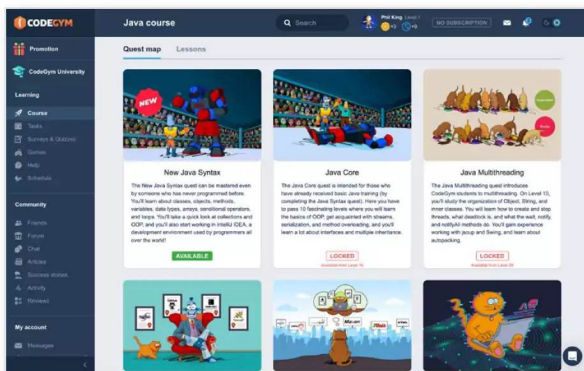

Further reading

Books to help you learn more about Java

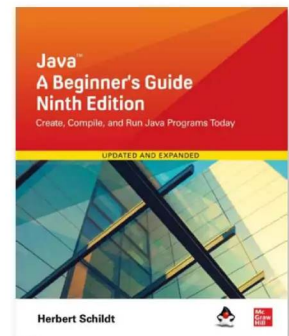

JAVA: A BEGINNER'S GUIDE

A comprehensive Java textbook, now in its ninth edition, it covers fundamentals, OOP, advanced topics and GUI development, with self-tests and projects.

► magpi.cc/javabeginners

INTRODUCTION TO JAVA PROGRAMMING AND DATA STRUCTURES

This hefty tome offers a fundamentals-first approach, integrating programming, data structures, and algorithms while emphasising problem-solving and practice.

► magpi.cc/introjva

EFFECTIVE JAVA

For seasoned Java developers seeking to improve their skills, this guide offers 90 best practices covering methods, generics, concurrency, and serialisation techniques.

► magpi.cc/effectivejava

Head First Java – 3rd Edition

AUTHOR

Kathy Sierra, Bert Bates, Trisha Gee

Price:
£64 / \$80

magpi.cc/headfirstjava3e

Aimed at absolute beginners, this 752-page book delivers a thorough introduction to object-oriented programming and Java. This third edition has been updated to cover Java versions 8 to 17. While pricey, it's currently available at a big discount.

Like other Head First books, it has a fun, visually rich format “designed for the way your brain works”, offering multiple learning styles. It's also written in an entertaining way with short stories, mysteries, and puzzles to help keep the reader engaged in the learning process. If other Java books or courses have left you befuddled, this could be the answer.

Chapters cover topics including classes, objects,

variables, inheritance, polymorphism, constructors, data structures, lambdas, streams, and a whole lot more. Each chapter features several exercises with solutions. **M**

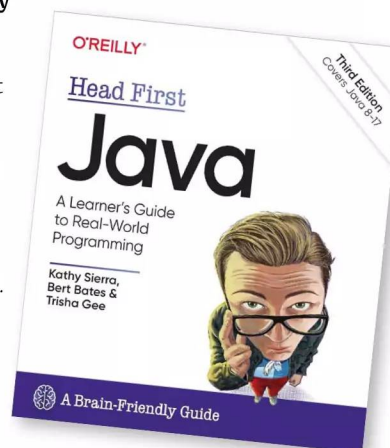



Brian O'Halloran

The Raspberry Pi Brand Manager helps makes sure everything you see is beautiful and consistent

> Name **Brian O'Halloran** | > Occupation **Brand Manager**
 > Community role **Raspberry Pi visuals** | > URL **raspberrypi.com**

We've been working with Brian ever since he joined Raspberry Pi as a photographer and videographer – both for covers, photos, and fun videos. We should get back to those videos one day, but his creativity and expertise have not only elevated the magazine but also everything you see out of Raspberry Pi.

“My career was born out of utter post-school indecision,” Brian admits. “I studied multimedia at uni, and even though it involved studying things like web development and data science, I decided that messing around with a camera was surely the most fool-proof way to make a living. I moved to Vancouver to ply my trade,

and was fortunate enough to get work in a great small video-production studio there. As well as corporate video, a considerable portion of my summers were spent filming weddings, to which I owe a considerable amount of my run-and-gun experience and a permanent shoulder weakness from carrying upwards of 10KG of camera gear in a tiny shoulder bag.”

When did you first learn about Raspberry Pi?

When I was in uni I had a lecturer with reasonably eccentric interests. At the time he was teaching us 2D animation, but it could easily have morphed into a class about botany or the history of zips. He once mentioned a thing called a Raspberry Pi in one of his classes, but I had just filed it under another one of his esoteric interests, not knowing the massive role it would play in my life years later.

Also, did you know that the modern zipper as we know it was first used in 1923?



▼ A personal photograph of Gyeongju-gi taken from South Korea

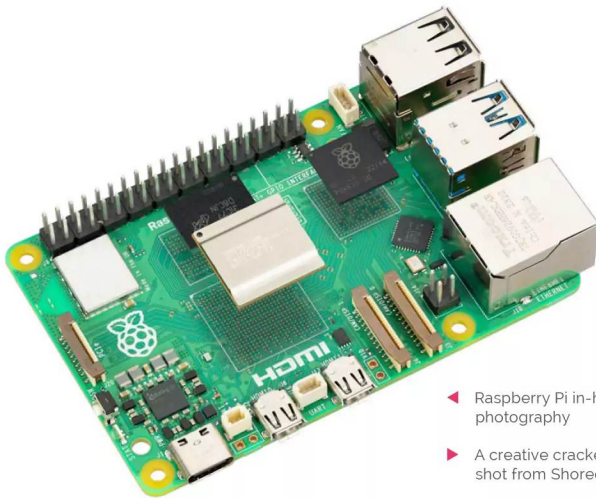

- ◀ Raspberry Pi in-house photography
- ▶ A creative cracked-mirror shot from Shoreditch

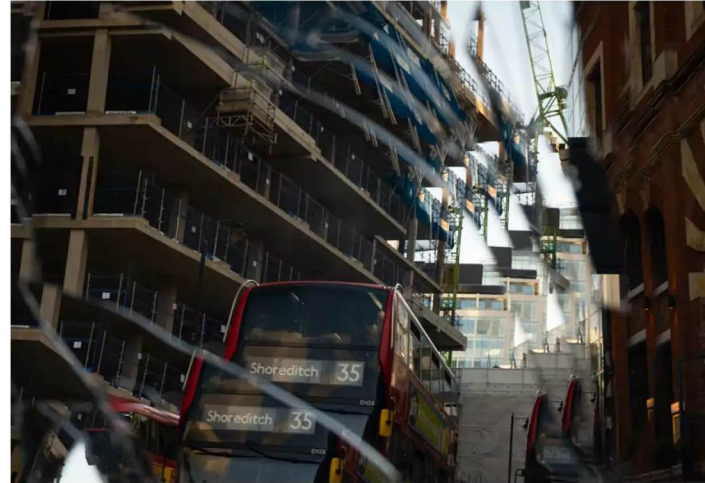

What's your favourite thing you've done with Raspberry Pi?

Overcome by intense paranoia before a holiday, I made a security camera that I could remotely access to check in on the house. Of course what I neglected to do was set it so that it stored photos on a server, but that was a great idea for version 2. Version 2 has yet to materialise.

What's your favourite uses of Raspberry Pi that you've seen?

As someone whose brain is 90% Simpsons quotes to the detriment of all other knowledge, seeing someone make the Simpsons TV that

plays the Simpsons non-stop was a source of immense joy. This is where I out myself as one of those tiresome people who say "ONLY SEASONS 3 TO 10 THOUGH PLEASE" (which I say because it is objectively correct) [Ed note: he's right].

What are some of your favourite videos/photos you've made for Raspberry Pi?

As someone dragged through the insidious mincer of the creative industry I am habitually incapable of finding nothing but fault in my own work. I am in a constant state of improvement and I would say that my most

“ The TV that plays the Simpsons non-stop was a source of joy ”

recent work is some of the stuff that I am most proud of. Raspberry Pi 5 stands out as a highlight, but mostly because it was such a collaborative experience with a lot of my very talented colleagues.

I did take the photo for the cover of the issue you're reading, so if you like that then that's cool. If you don't, well, thankfully you can't leave a comment on a magazine. 📷

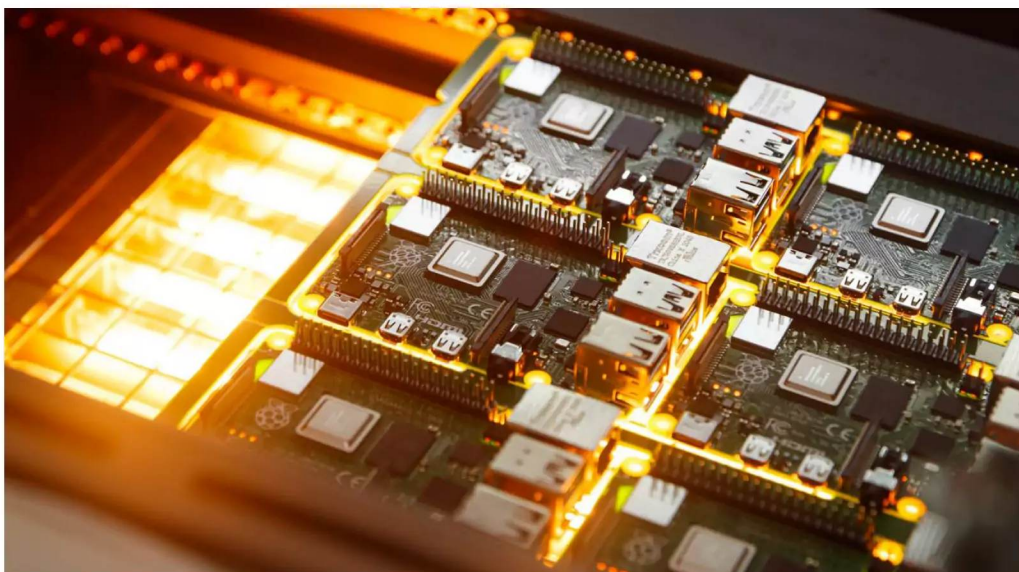

- ◀ Raspberry Pi 4 boards being soldered on the line at Sony Pencoed factory, Wales

Events in pictures: Mayday Pi Jam in Leicester

Community and official events in the wild

Held at Leicester Hackspace, this event focussed on camera projects, with members of the hackspace old and new (and lapsed!) coming along to see some cool projects. Here's a small report from the event organiser Steve Gale.

"The All Sky camera was popular, with images from Leicestershire, plus some photos taken in South Australia with an identical device, We were all jealous of the photos of the milky way! We also had a Raspberry Pi 5 controlling a servo using gestures, based on one of "Kevs robots" projects, plus a USB controlled arm. Another member set up retro-pie. Our youngest member Anna showed off her nature cam using a Raspberry Pi Zero W."

FIND OUT ABOUT
NEXT MONTH'S EVENTS
AND POP-UPS ON
PAGE 92



- 01. The All Sky camera has been featured before in the magazine – it's an all-weather long exposure astrophotography project
- 02. PiFinder is also an astronomy build, allowing you to look at and track celestial bodies as they move through the night sky
- 03. Apparently 25 people came to the makerspace throughout the day
- 04. Other projects were on display for people to look at

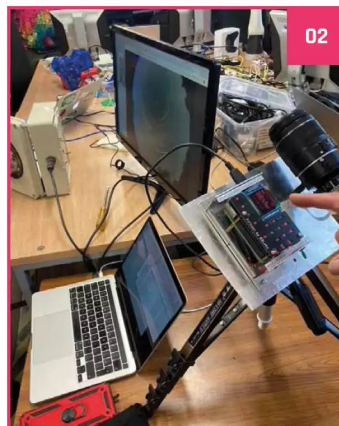



- ◀ It's quite compact in a car, and modern cars seem to have an abundance of USB ports to use too
- ▼ The bill of materials is very small - it's mostly software

Offline GPS tracking

Track your movements and map your past route, no mobile internet required

D arko Golner from Croatia emailed us with his comprehensive tutorial for creating something he calls *raspi-gps*.

“This simple project *raspi-gps* is a small GPS tracking system I made using Raspberry Pi and an external GPS Bluetooth module,” Darko writes on his GitHub. “This device is conceived as offline tracking, just connect it to a USB in the car, turn it on and record movement without connecting to the Internet. Since the movement (change of GPS position in time) is recorded in the form of GPX files on the SD card, it’s possible to load such routes in external applications such as Google Earth by downloading from the SD card.”

He’s not kidding when he says its comprehensive – the GitHub page (magpi.cc/raspigps) is very detailed, with all the code open source and ready to use. Happy tracking.

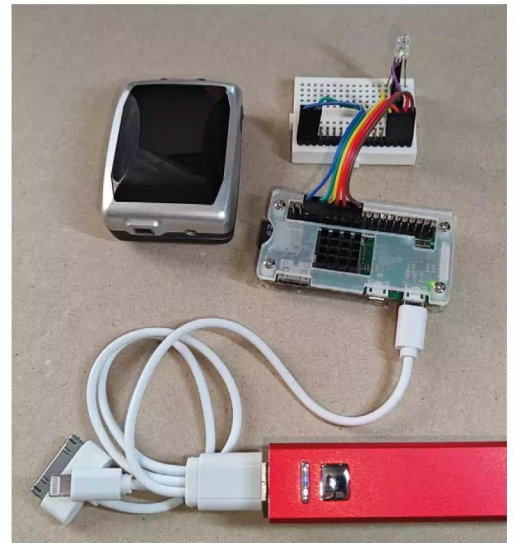

- ▼ Using a Raspberry Pi Zero keeps it very compact

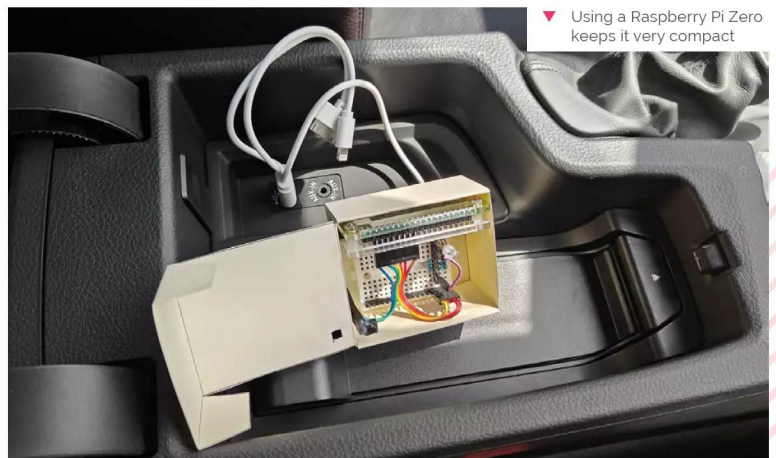

MagPi Monday

Amazing projects direct from social media!

Every Monday we ask the question: have you made something with a Raspberry Pi over the weekend? Every Monday, our followers send us amazing photos and videos of the things they've made.

Here's a selection of some of the awesome things we got sent this month. Remember to follow along at the hashtag #MagPiMonday!

01. This PCB has escaped the confines of the Raspberry Pi footprint in pursuit of greater musical fidelity
02. Hook this up to a VR headset and you could feasibly ride your own rails
03. Very pretty lights! Reusable for Christmas as well – although we wouldn't personally sleep in a tent in December
04. I wonder if we can ask it to be big and dance on a piano with Robert Loggia
05. Yep, this looks perfectly normal for Jeff – carry on
06. The CinePi range of cameras always seem to be getting better and better

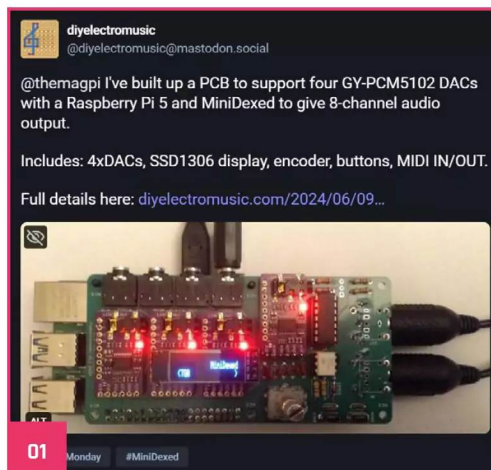
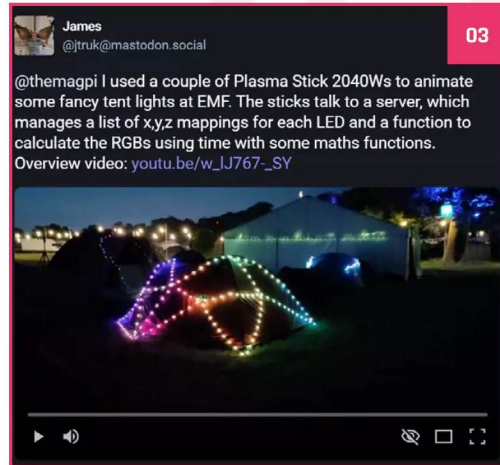

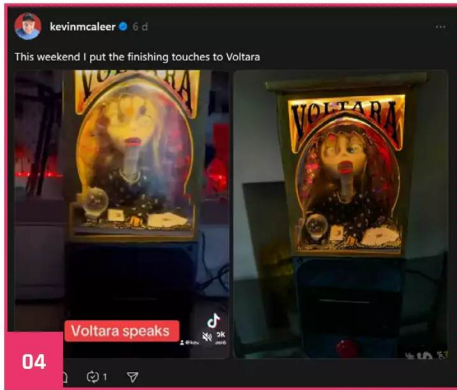

04



05



06

Crowdfund this

Raspberry Pi projects you can support this month

PiWings 2.0



PiWings 2.0 is finally live, this custom flight controller for Raspberry Pi Pico-powered drones is designed specifically for educational purposes but we won't tell anyone if you use it to make a cheap, light drone for you to play around with

► kck.st/3x6epnY

CodeRover ATV & Snowcat



The latest CodeRover is a beefy looking robot, with its friend Snowcat complete with treads for rough terrains – maybe this would be a good platform for a science smart robot. They come with the ability to add a huge number of add-ons, and are fully programmable.

► magpi.cc/coderoveratv

Your Letters

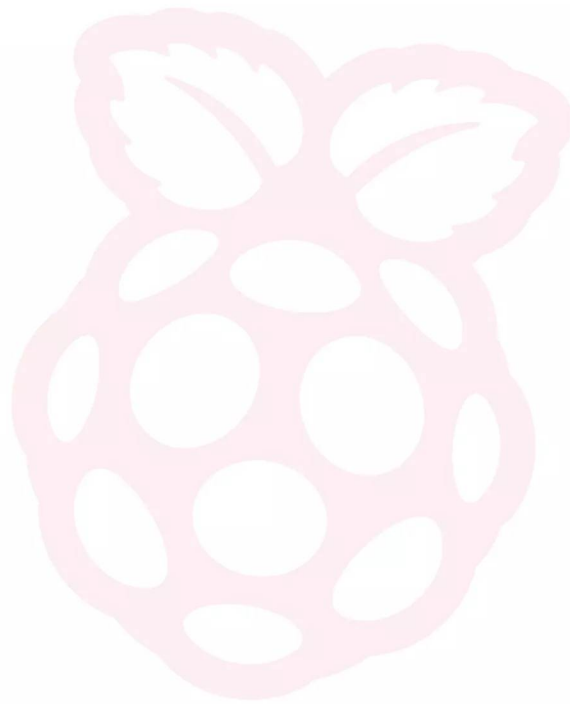

Upgrade worries

I'm worried, and maybe others are too. Or have I misunderstood something? I have a nice Raspberry Pi 5 8GB with M.2 HAT+. I'm booting from the M.2 and took out the microSD card. So I've loaded up Apache and MySQL and some web pages and various other software and lots of MP3s, and am about to play with AI. I'm running Bullseye... but what happens when I want to upgrade to Bookworm? The recommended route seems to be to use Imager... but won't I lose everything I installed?

I'm not sure I'm up to a manual update – possibly `rp-update` – but I'd feel safer doing that and a backup with you holding my hand. Can you show me (and others) how please?

Paul via email

Updating Raspberry Pi OS, which is based on Debian Linux, is a little different to doing the same thing in Windows. Depending on how you use it, you won't necessarily need to update it anyway. However, if you want you can get some more software updates by using the command `sudo apt dist-upgrade` instead of `upgrade` in the command line.

If you decide you do want to update to the next version of Raspberry Pi OS properly, though, you will need to install it from scratch. Luckily, you can back up your Home folder, along with settings for important apps, and return most of them once installed. It's likely you will have to set up some of your software again though.

We haven't done a backup article in a while though, so perhaps that is something for the future!

► Due to the way Linux works, you can't always update Raspberry Pi OS in the same way as other operating systems

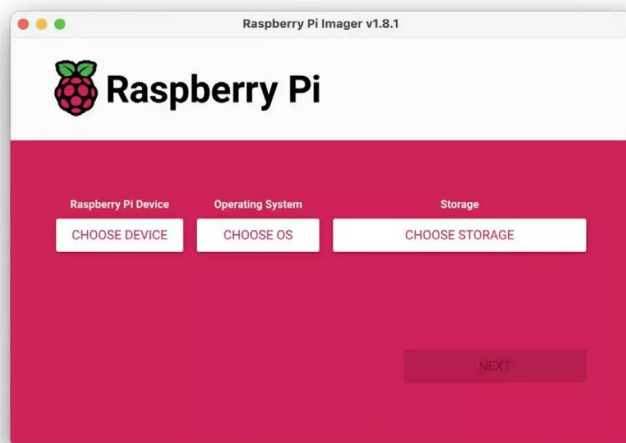

More a message of support

I love to have your magazines in paper form, sadly I can't afford to buy them all every month so rely on the PDFs (they're also SOOO much easier to store).

The decision to not make them available right away seemed like a shame, but thinking about it, I whole heartedly support the idea. Waiting a little while doesn't make the magazines any less useful or informative.

Thank you all for the amazing magazines and articles.

Ben via email

Yes storing the PDFs is much easier – over time we find ourselves checking the PDFs more than the physical references ourselves! If you keep an eye on the blog, content from the current issue also makes its way there, so you can read a good portion of the magazine ahead of the free PDF release.

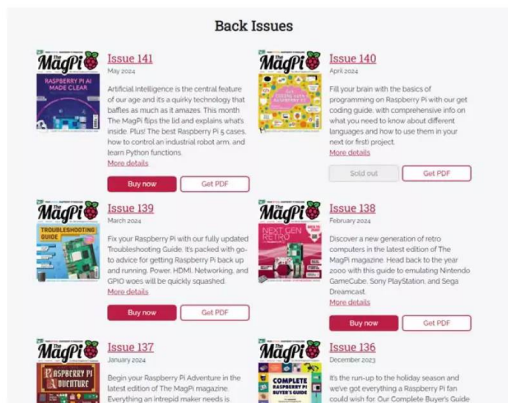

▲ Our back issues aren't going anywhere either

Contact us!

- ▶ Mastodon magpi.cc/mastodon
- ▶ Threads @themagpimag
- ▶ Facebook magpi.cc/facebook
- ▶ Email magpi@raspberrypi.com
- ▶ Online forums.raspberrypi.com

USA SPECIAL!

6 ISSUES

FOR \$43



FREE RASPBERRY PI PICO W



Subscribe online:
magpi.cc/subscribe

Continuous credit card orders will auto-renew at the same price unless cancelled.
A free Pico W is included with all subscriptions. This is a limited offer.
Not included with renewals. Offer subject to change or withdrawal at any time.



Community Events Calendar

Find out what community-organised Raspberry Pi-themed events are happening near you...

01. Melbourne Raspberry Pi Meetup

- 📅 Sunday 7 July
- 📍 107 Victoria Harbour Promenade, Melbourne, Australia
- ➡ magpi.cc/mrpm143

This meetup is open to everyone with an interest in electronics, robotics, home automation, 3D printing, laser cutting, amateur radio, high altitude balloons, space tech, etc. Makers are invited to bring along their projects and project ideas, and come connect with other makers. Get your questions answered, show off the work you are doing, and get support to resolve nagging issues.

02. Japanese Raspberry Pi Users Group at Open Source Conference Kyoto 2024

- 📅 Saturday 27 July
- 📍 Kyoto Research Park, Kyoto, Japan
- ➡ magpi.cc/jrpug143

Japanese Raspberry Pi Users Group is coming to the Open Source Conference in Kyoto in June! We will exhibit Raspberry Pi 5 and Raspberry Pi use cases. Please join if you live in the Kansai area of Japan!



03. Experience Raspberry Pi @ Purple Space

- 📅 Sunday 7 July
- 📍 Purple Space Library, Udupi, India
- ➡ magpi.cc/ps143

Raspberry Pi enthusiasts come together to share their passion for creating and designing projects with Raspberry Pi technology. This is an opportunity to empower young minds to learn computing using Raspberry Pi and become confident innovators and creative digital makers. Get to see the newest addition to the Raspberry Pi product family, the Raspberry Pi AI Kit with the Hailo-8L co-processor, a 13 trillion operations per second (TOPS) neural processor, making edge machine learning and computer vision much faster on a Raspberry Pi.

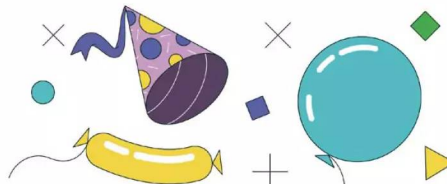

04. Riverside Raspberry Pi Meetup

- 📅 Monday 8 July
- 📍 3600 Lime Street, Riverside, CA, USA
- ➡ magpi.cc/rrpm143

The purpose of Riverside Raspberry is to share knowledge related to Raspberry Pi hardware in particular, and to promote interest in tech development in the Inland Empire in general. The group is currently meeting on the second Monday evening of every month.

FULL CALENDAR

Get a full list of upcoming community events here:

magpi.cc/events



MAKER FAIRE HANNOVER



Maker Faire Hannover

- ▶ Where Hannover Congress Centrum, Hannover, Germany
- ▶ When Saturday 17 August and Sunday 18 August



We're proud to partner with Raspberry Pi Approved Reseller BerryBase to be at Maker Faire Hannover for the second year in a row. Come and meet members of the Raspberry Pi team, learn about our latest products, and share what you've made with Raspberry Pi technology.

magpi.cc/mfh24

WIN ONE OF FIVE

RASPBERRY PI AI KITS

Hot on the heels of the M.2 HAT+ is the full AI Kit in collaboration with Hailo and featuring the Hailo-8L AI accelerator module. Use it for local machine learning and neural networks that work great with AI vision via a Raspberry Pi Camera Module.

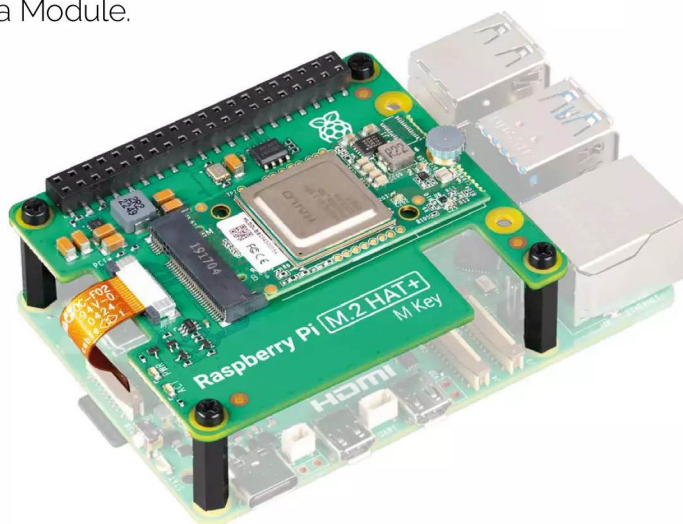

Head here to enter: magpi.cc/win | Learn more: magpi.cc/aikit

Terms & Conditions

Competition opens on **26 June 2024** and closes on **25 July 2024**. Prize is offered to participants worldwide aged 13 or over, except employees of Raspberry Pi Ltd, the prize supplier, their families, or friends. Winners will be notified by email no more than 30 days after the competition closes. By entering the competition, the winner consents to any publicity generated from the competition, in print and online. Participants agree to receive occasional newsletters from *The MagPi* magazine. We don't like spam: participants' details will remain strictly confidential and won't be shared with third parties. Prizes are non-negotiable and no cash alternative will be offered. Winners will be contacted by email to arrange delivery. Any winners who have not responded 60 days after the initial email is sent will have their prize revoked. This promotion is in no way sponsored, endorsed or administered by, or associated with, Instagram, Facebook, Threads, or any other companies used to promote the service.

THE *Official*

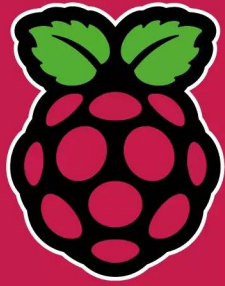

RASPBERRY PI HANDBOOK

2024

200 PAGES OF RASPBERRY PI

- QuickStart guide to setting up your Raspberry Pi computer
- Updated with Raspberry Pi Pico and all the latest kit
- The very best projects built by your Raspberry Pi community
- Discover incredible kit and tutorials for your projects

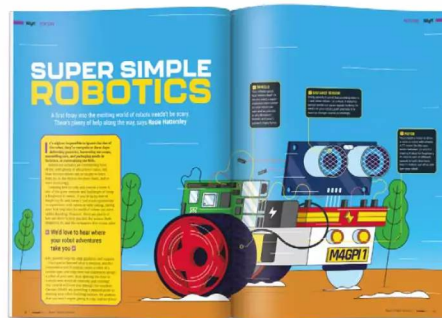
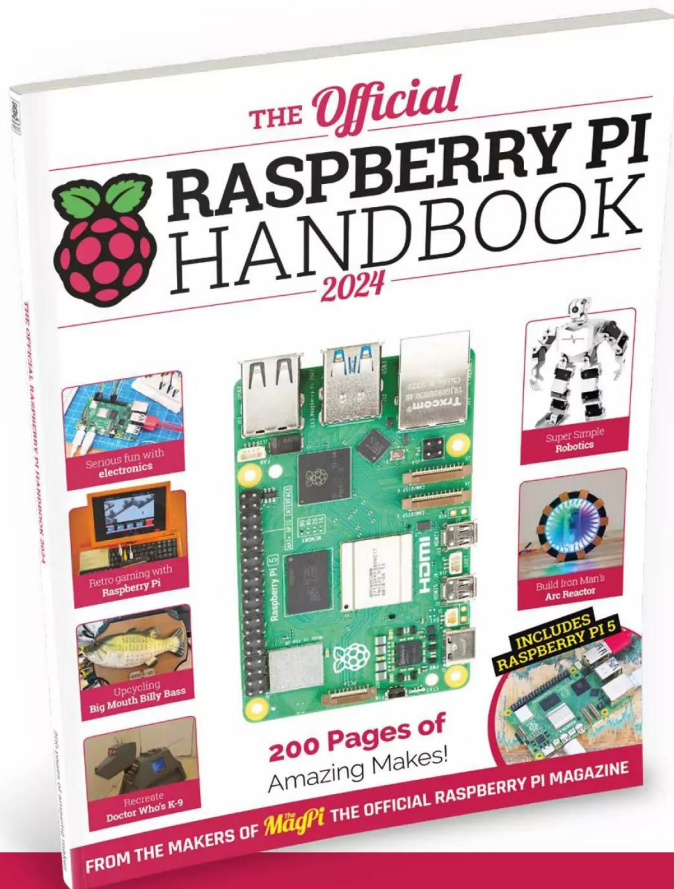

Buy online: magpi.cc/store

HackSpace

TECHNOLOGY IN YOUR HANDS

THE MAGAZINE FOR THE MODERN MAKER



ISSUE #80
OUT NOW

hsmag.cc





SMART ELECTRONICS

Boost your projects with wires, buttons, and components!

The MagPi #144
On sale **25 July**

Plus!

Photography
projects

**Talking
tomato plants**

Learn to
code with C

DON'T MISS OUT! magpi.cc/subscribe

MASTODON magpi.cc/mastodon

THREADS [@themagpimag](https://www.threads.net/@themagpimag)

FACEBOOK magpi.cc/facebook

EMAIL magpi@raspberrypi.com

ONLINE forums.raspberrypi.com

EDITORIAL

Editor
Lucy Hattersley
lucy@raspberrypi.com

Features Editor
Rob Zwetsloot
rob@raspberrypi.com

Sub Editor
Ian Evenden

ADVERTISING

Charlotte Milligan
charlotte.milligan@raspberrypi.com
+44 (0)7725 368887

DESIGN

Head of Design
Jack Willis

Designers
Sara Parodi, Natalie Turner

Illustrator
Sam Alder

Photographer
Brian O'Halloran

CONTRIBUTORS

James Adams, Nate Contino,
David Crookes, PJ Evans,
Rosemary Hattersley, Phil King,
Dr Andrew Lewis, Sean McManus,
Naush Patuck

PUBLISHING

Publishing Director
Brian Jepson
brian.jepson@raspberrypi.com

Director of Communications
Liz Upton

CEO
Eben Upton

DISTRIBUTION

Seymour Distribution Ltd
2 East Poultry Ave,
London EC1A 9PT
+44 (0)207 429 4000

SUBSCRIPTIONS

Unit 6 The Enterprise Centre
Kelvin Lane, Manor Royal,
Crawley, West Sussex, RH10 9PE
+44 (0)1293 312193
magpi.cc/subscribe
magpi@subscriptionhelpline.co.uk



This magazine is printed on paper sourced from sustainable forests and the printer operates an environmental management system which has been assessed as conforming to ISO 14001.

The MagPi magazine is published by Raspberry Pi Ltd, 194 Cambridge Science Park, Milton Road, Cambridge, England, CB4 0AB. The publisher, editor, and contributors accept no responsibility in respect of any omissions or errors relating to goods, products, or services referred to or advertised in the magazine. Except where otherwise noted, content in this magazine is licensed

under a Creative Commons Attribution-NonCommercial-ShareAlike 3.0 Unported (CC BY-NC-SA 3.0).
ISSN: 2051-9982.





Public

Raspberry Pi has hit the stock market. **Rob Zwetsloot** finds out what this means

If you've been reading the financial papers over the last few months, you'll have been aware that Raspberry Pi was looking to float on the stock market. This is, understandably, quite a big deal, so when I got the email sent around to staff asking if they'd want to go to the London Stock Exchange for 7:45 AM on a Tuesday morning for the launch, I gracefully... declined.

Unfortunately, my car was due to be returned to me after some repairs (hit and run on the motorway at 70; I was fine, my car not so much), and also, I didn't really fancy getting up at 3am to get to London in time. Lucy went though, so there was *The MagPi* representation there for the big moment where the button was pressed to open the market. The video feed made the whole thing look very cool, with fancy light displays and video to signify the event. I wonder if the City uses Raspberry Pi for that – it would be very fitting.

Evolution

"This is a watershed moment for Raspberry Pi," Eben posted on Raspberry Pi dot com that morning.

"And the start of a new phase in our evolution: access to the public market will enable us to build more of the products you love, faster. And the money raised by the Raspberry Pi Foundation in the IPO will support its ambitions for global impact in its second decade."

Philip Colligan, CEO of the Raspberry Pi Foundation wrote in a post a couple of weeks ago just how that would work: "To date,

“ Money raised by the Raspberry Pi Foundation in the IPO will support its ambitions for global impact in its second decade ”

Raspberry Pi Ltd has donated nearly \$50m from its profits to the Foundation, which we have used to advance our educational mission combined with over \$60m in funding from philanthropy, sponsorship, and contracts for educational services," he wrote. "From the Foundation's perspective, an IPO provides us with the ability to sell some of our shares to raise money

to finance a sustainable expansion of our educational activities. Put simply, instead of receiving a share of the company's profits each year, we will convert some of our shareholding into an endowment that we will use to fund our educational programmes."

What's next

There's been a whole lot of work behind the scenes for this for some time now – I've only caught glimpses on my monthly visits to Raspberry Pi Towers – so hopefully some of that pressure has now been alleviated. I'll find out on my next visit.

Anyway, I thought I'd talk about it here as for various reasons we've not had a chance to mention it elsewhere in the magazine [lots of exciting new opportunities to end up in front of a judge – Ed]. Also, my car got returned the following day and now I sort of regret not having got up early for it. Ah well – onwards. 📺

Rob Zwetsloot

Rob is the Features Editor of *The MagPi* and is too fond of sleep

magpi.cc

AUTHOR

HIGHPI PRO

————— The new case from the HiPi.io team —————.



- Rapid tool-free assembly and disassembly
- Large internal volume for HATs
- Compatible with Pi 2/3/4
- Multiple lid options
- Passive & Active Cooling options
- Secure microSD card cover
- VESA mount support
- Molding-configurable output ports customizable for volume orders
- Printed logo for your branding

Available at these great Pi stores:



Contact your favorite Pi store if it's not listed here

PiKVM

Remote control **redefined**

Manage your
servers or PCs
remotely!



PiKVM V4 Mini

Small, cost-effective, and powerful!

- Power consumption in idle mode: just 2.67 Watts!
- Transfer your mouse and keyboard actions
- Access to all configuration settings like UEFI/BIOS
- Capture video signal up to 1920x1200@60 Hz
- Take full control of a remote PC's power

PiKVM V4 Plus

The most feature-rich edition

- More connectivity
- Extra storage via internal USB 3.0
- Upgraded powering options
- More physical security features
- Extra HDMI output
- Advanced cooling solution



A cost-effective solution for data-centers,
IT departments or remote machines!

Available at the main Raspberry Pi resellers



HiPi.io

No reseller in your country?
Check shop.hipi.io (import fees might apply).

List of official
resellers by country:

